



Read the operating instructions prior to commissioning

FlexFusion® ELECTRIC GOLD COMBI



Installation manual

Model

FGE-615
FGE-621
FGE-115
FGE-121
FGE-215
FGE-221



Henny Penny Corporation
P.O.Box 60
Eaton, OH 45320
USA

Phone +1 937 456-8400
Fax +1 937 456-8402

Toll free in USA
Phone +1 937 417-8417
Fax +1 937 417-8434

www.hennypenny.com

1 Introduction	5
1.1 About this manual	5
1.1.1 Explanation of signs	6
1.2 Personnel qualifications	7
1.3 Use of the unit	7
1.4 Warranty	7
2 Safety instructions	8
3 Description of the unit	10
3.1 Overview of the unit	10
3.1.1 Countertop unit	10
3.1.2 Floor-standing unit	11
3.2 Planning drawing	12
3.3 Unit and connection data	13
4 Transporting the unit	18
4.1 Transporting the unit to the installation site	18
4.2 Unpacking the unit	19
5 Installing the unit	20
5.1 Minimum clearances	21
5.2 Lifting the unit off the pallet	22
5.3 Installing the unit on the unit legs	22
5.4 Setting up the unit on a base frame	23
5.4.1 Installing the support rack	24
5.5 Aligning the unit	24
5.5.1 Aligning countertop unit	24
5.5.2 Aligning a floor-standing unit	24
5.6 Fastening the unit to the floor	26
5.6.1 Securing the unit to prevent tipping	26
5.6.2 Securing the unit to prevent slipping	29
6 Connecting the unit	31
6.1 Opening and closing the housing	31
6.1.1 Removing and attaching the side wall	31
6.2 Making the electrical connection	32
6.2.1 Adjusting the unit to the supply voltage	34
6.2.2 Connecting the electrical connection line	35
6.2.3 Connecting the power optimization system	36
6.2.4 Connecting the potential equalization	37
6.3 Performing the basic setting of the control	38
6.3.1 Opening the Setting menu	38
6.3.2 Changing the basic setting of the control	39
6.4 Making the water connection	39

6.4.1 Connecting the drinking water connection line	40
6.4.2 Connecting softened drinking water to both connections	41
6.5 Making the waste water connection	42
6.5.1 Determining the type of connection to the sewer system	42
6.5.2 Connecting the waste water line to a permanent connection	43
6.5.3 Connecting a waste water line with an unobstructed discharge	44
6.6 Making the exhaust air connection	44
6.6.1 Connecting the exhaust air line	45
7 Testing the function	46
7.1 Checking the controls	46
7.2 Checking the inspection of the cooking chamber door	46
7.3 Heating and rinsing the unit	47
8 Putting the unit into service	48
8.1 Nameplate	48
8.2 Filling out the Start-up operation report	49

1 Introduction

1.1 About this manual

The installation instructions are part of the unit and contain information on safe installation of the unit.

Observe the following notes and adhere to them:

- Read the installation instructions completely prior to installation.
- Make the installation instructions available to the installation fitter at the operating site at all times.
- Preserve the installation instructions throughout the service life of the unit.
- Insert any additions from the manufacturer.
- Pass on the installation instructions to any subsequent operator of the unit.

Target group The target group of the installation instructions is trained qualified personnel that is familiar with installing and operating the unit.

Figures All figures in this manual are intended as examples. Discrepancies can arise between this and the actual unit.

1.1.1 Explanation of signs

 **DANGER**

Imminent danger

Failure to comply will lead to death or very severe injuries.

 **WARNING**

Potential danger

Failure to comply can lead to death or very severe injuries.

 **CAUTION**

Dangerous situation

Failure to comply can lead do slight to moderately severe injuries.

NOTICE

Property damage

Failure to comply can cause property damage.

INFORMATION

Information

Notes for better understanding and operation of the unit.

Symbol / sign	Meaning
•	Listing of information.
→	Action steps which can be performed in any sequence.
1. 2.	Action steps which must be performed in the specified sequence.
↳	Result of an action performed or additional information relating to it.

1.2 Personnel qualifications

Explanation of qualification

Skilled personnel	<ul style="list-style-type: none"> • A skilled person is someone who, on the basis of their technical training, knowledge and experience as well as familiarity with the applicable standards, can assess the assigned work and recognize possible dangers.
-------------------	--

Type of activity	Qualification
Electrical connection	<ul style="list-style-type: none"> • Electrician • Specialized training • Employee of the responsible technical company
Water connection	<ul style="list-style-type: none"> • Water specialist • Specialized training • Employee of the responsible technical company
Waste water connection	<ul style="list-style-type: none"> • Waste water specialist • Specialized training • Employee of the responsible technical company

1.3 Use of the unit

This unit is intended to be used solely for commercial purposes, particularly in commercial kitchens.

1.4 Warranty

The warranty is void and safety is no longer assured in the event of:

- Improper conversion or technical modifications of the unit,
- Improper use,
- Improper startup, operation or maintenance of the unit,
- Problems resulting from failure to observe these instructions.

2 Safety instructions

The unit complies with applicable safety standards. Residual risks associated with operation or risks resulting from incorrect operation cannot be ruled out and are mentioned specifically in the safety instructions and warnings.

The installation fitter must be familiar with regional regulations and observe them.

The installation fitter must observe the safety instructions in these installation instructions and in the "Safety information" chapter of the operating instructions.

Ensuring conformity with standards Observe applicable international, European and national laws, regulations, standards and directives for the unit when transporting, setting up and connecting it.

Improper installation Risk of property damage and personal injury from improper installation

- Install the unit only as specified in these installation instructions.
- Do not add anything to the unit or modify the unit.
- Use only original spare parts.

Transportation and storage Risk of personal injury and property damage from improper transportation and improper storage

- Store the unit in a dry, frost-free environment.
- Observe the safety regulations for the lifting gear used.
- Attach the unit to the lifting gear securely during transport and installation, and prevent it from dropping.
- Transport the unit in an upright position, do not tilt or stack.
- Pay attention to protruding parts when transporting the unit without packaging.

Fire prevention Risk of fire from combustible surfaces

- Observe general fire prevention regulations.

Organizational measures Risk of property damage and personal injury from lack of organizational measures

- Identify danger zones when transporting, installing and connecting the unit.
- Prior to starting the installation tasks, notify any operator present about the procedure.
- Prior to starting the installation task, discuss how to behave in an emergency.
- Use equipment and protective gear suitable for the activity.
- Brace housing components to prevent them from falling over and dropping.

Installation Risk of property damage and personal injury from improper installation

- Ensure that the installation area has adequate load-bearing capacity.
- Wear safety shoes and protective gloves.

Electrical connection Risk of fire from improper connection

- Observe applicable regional regulations of the electric supplier.
- Ensure that only electricians licensed by the electric supplier connect the unit.
- Ensure that the electrical system is earthed by a protective earthing conductor.
- Note the information on the nameplate.

Danger of electric shock from live components.

- Prior to working on the electrical system, switch off the unit, disconnect the electrical system from the mains and prevent power from being switched on again. Check to ensure the system is dead.
- Use only insulated tools.

Unit on casters Danger of a line breaking if subjected to high tensile load

- Secure the unit with a chain as a strain relief for the connection line at the installation site so that no tensile load is applied to the connection line if the unit is moved.

Commissioning Risk of property damage and personal injury from improper commissioning

- Read the operating instructions prior to commissioning. Observe the safety instructions in these installation instructions and in the "Safety information" chapter of the operating instructions.
- Only put the unit into service after a successful function test in its assembled state.
- Put the unit into service only after it has reached room temperature.
- Observe the units during operation.

3 Description of the unit

3.1 Overview of the unit

3.1.1 Countertop unit

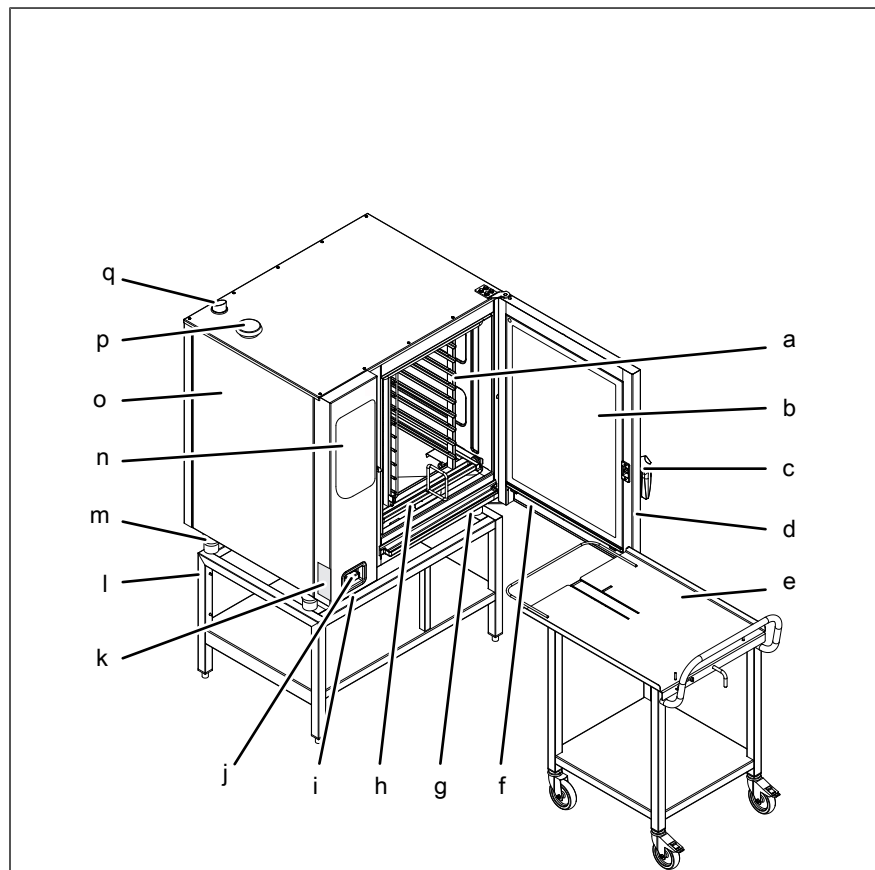

Image: Image: Unit with tray rack trolley

- | | | | |
|---|-------------------------------------|---|-------------------------------|
| a | Tray rack | j | Hand shower |
| b | Insulating disk | k | Nameplate |
| c | Door handle | l | Base frame (optional) |
| d | Cooking chamber door | m | Unit foot |
| e | Tray rack trolley (optional) | n | Operating element |
| f | Vapor drainage channel, door | o | Housing |
| g | Vapor drainage channel, unit | p | Air intake connection fitting |
| h | Guide rail for tray rack (optional) | q | Steam outlet nozzle |
| i | USB port (covered) | | |

3.1.2 Floor-standing unit

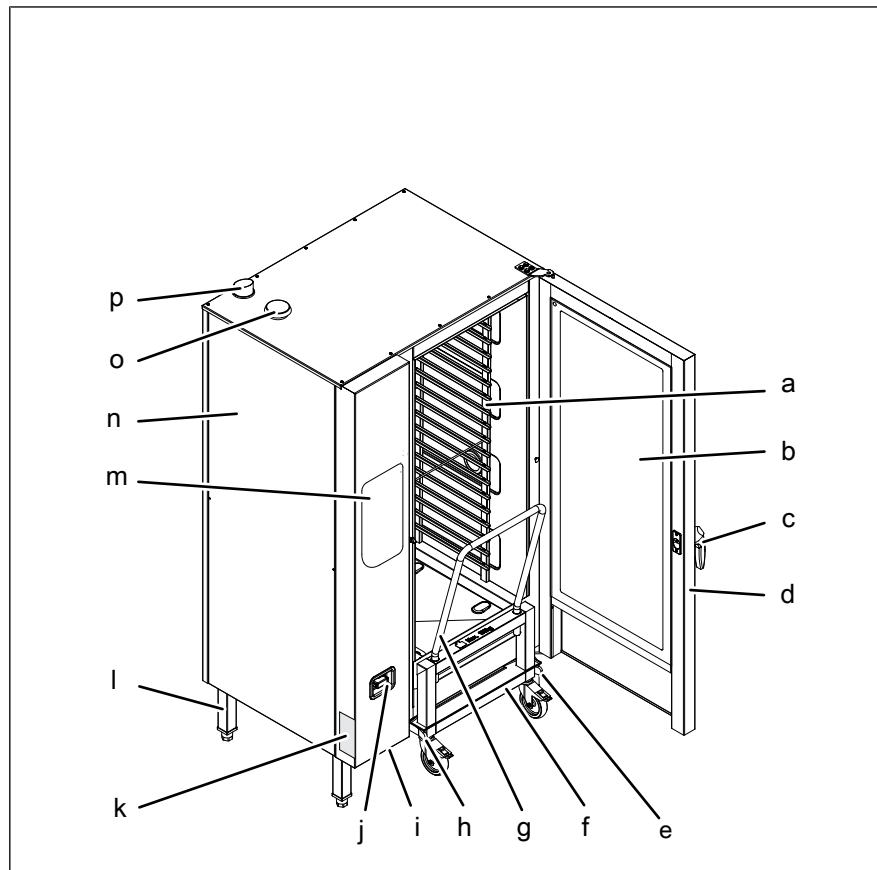

Image: Image: Unit with tray trolley

- | | | | |
|---|----------------------|---|---------------------|
| a | Tray rack | i | USB port (covered) |
| b | Insulating disk | j | Hand shower |
| c | Door handle | k | Nameplate |
| d | Cooking chamber door | l | Unit leg |
| e | Guide rail (right) | m | Operating unit |
| f | Tray trolley | n | Housing |
| g | Handle bar | o | Air inlet nozzle |
| h | Guide rail (left) | p | Steam outlet nozzle |

3.2 Planning drawing

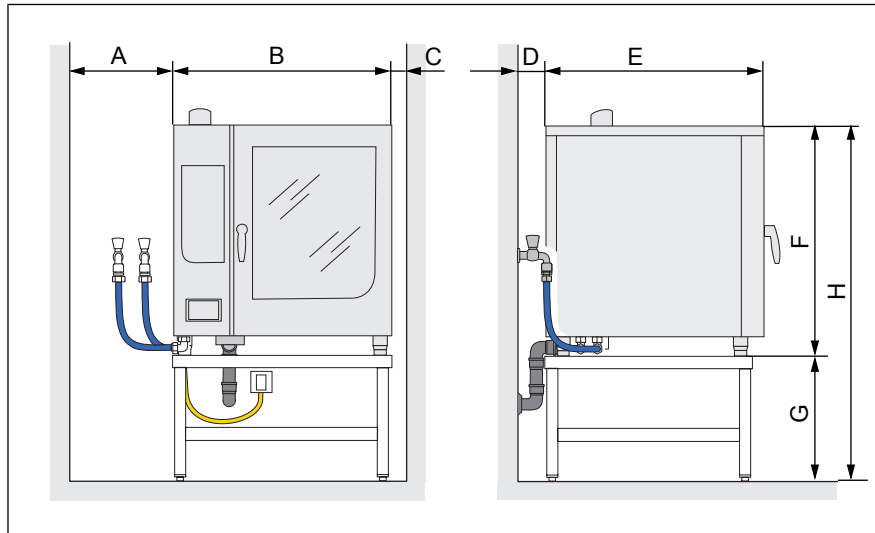

Image: Sizes 6XX and 1XX

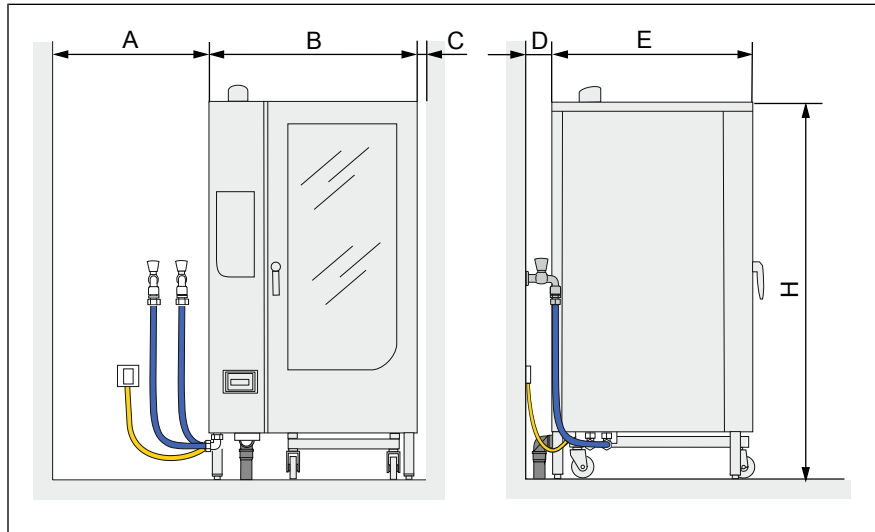

Image: Size 2XX

Size	615, 621	115, 121	215, 221
A	50 (1,97)	50 (1,97)	50 (1,97)
B	997 (39,25)	997 (39,25)	1075 (42,32)
C	50 (1,97)	50 (1,97)	50 (1,97)
D	50 (1,97)	50 (1,97)	50 (1,97)
E	799 (31,46)	799 (31,46)	813 (32,01)
F	790 (31,1)	1060 (41,73)	---
G	850 (33,46)	580 (22,83)	---
H	1640 (64,57)	1640 (64,57)	1960 (77,17)
All dimensions in mm (in)			

3.3 Unit and connection data

Size	615	621	115	121	215	221
Dimensions						
Unit Length x Width x Height (mm (in))	997 (39,25) x 799 (31,46) x 790 (31,1)		997 (39,25) x 799 (31,46) x 1060 (41,73)		1075 (42,32) x 813 (32,01) x 1960 (77,17)	
Weight						
Unit (kg (lb))	120 (264,6)	125 (275,6)	140 (308,7)	145 (319,7)	305 (672,5)	313 (690,2)
Emissions						
Latent heat (W)	1780	3670	2750	5400	5510	10200
Sensible heat dissipation (W)	1190	2450	1840	3600	3670	7100
Noise level (db(A))	< 70					
The listed value is reduced by 80% when working with a condensation hood; the sensible heat dissipation is increased by the amount of the reduction.						
The sensible and latent heat amounts are determined in Germany on the basis of VDI 2052 at a connection voltage of 400 V. The applicable regional regulations may vary from this.						
Operating environment						
Temperature (°C (°F))	5 (41) — 40 (104)					
Humidity (%) non-condensing	95					
Electrical connection						
Protection class	IPX5, IPX6 (optional)					
Type of connection	3PE / AC 50/60Hz, 3NPE / AC 50/60Hz					
Voltage (V)	200					
Connected load (kW)	10.1	16.3	14.7	25.5	29.4	50.9
Fuse (A)	3 x 35	3 x 50	3 x 50	3 x 80	3 x 100	3 x 180
Voltage (V)	208					
Connected load (kW)	10.2	17.4	15.7	27.3	31.4	54.6
Fuse (A)	3 x 35	3 x 50	3 x 50	3 x 80	3 x 100	3 x 180
Voltage (V)	220					
Connected load (kW)	11.6	19.7	17.7	30.8	35.4	61.4
Fuse (A)	3 x 35	3 x 63	3 x 63	3 x 100	3 x 125	3 x 180
Voltage (V)	230					
Connected load (kW)	12.6	21.4	19.3	33.6	38.6	67
Fuse (A)	3 x 35	3 x 63	3 x 63	3 x 100	3 x 125	3 x 180
Voltage (V)	240					
Connected load (kW)	13.7	23.3	21	36.5	42	72.9
Fuse (A)	3 x 35	3 x 63	3 x 63	3 x 100	3 x 125	3 x 180
Voltage (V)	380					
Connected load (kW)	9.4	18.9	14.4	27.6	28.7	55

Description of the unit

Size	615	621	115	121	215	221
Fuse (A)	3 x 16	3 x 35	3 x 25	3 x 50	3 x 50	3 x 100
Voltage (V)	400					
Connected load (kW)	10.4	20.9	15.9	30.5	31.7	60.9
Fuse (A)	3 x 16	3 x 35	3 x 25	3 x 50	3 x 50	3 x 100
Voltage (V)	415					
Connected load (kW)	11.2	22.5	17.1	32.8	34.1	65.5
Fuse (A)	3 x 16	3 x 35	3 x 25	3 x 50	3 x 50	3 x 100
Voltage (V)	440					
Connected load (kW)	10.4	20.9	15.8	30.5	31.5	60.9
Fuse (A)	3 x 16	3 x 35	3 x 25	3 x 50	3 x 50	3 x 100
Voltage (V)	480					
Connected load (kW)	12.3	20.9	18.9	32.6	37.6	65.1
Fuse (A)	3 x 16	3 x 35	3 x 25	3 x 50	3 x 50	3 x 100
Softened drinking water connection						
Type of water	Softened drinking water, cold					
Carbonate hardness CaCO ₃ (mmol/l (ppm))	< 0,9 (90 ppm)					
Chloride Cl (mg/l)	< 100					
Iron Fe (mg/l)	< 0.2					
Connection pressure (kPa (psi))	200 (29) — 600 (87)					
Connection (")	R 3/4					
Drinking water connection						
Type of water	Drinking water, cold					
Carbonate hardness CaCO ₃ (mmol/l (ppm))	< 4 (400 ppm)					
Connection pressure (kPa (psi))	200 (29) — 600 (87)					
Connection (")	R 3/4					
Water consumption for steaming						
Softened drinking water (l/h (gal/h))	16 (4,23)	21 (5,55)	18 (4,76)	24 (6,34)	36 (9,51)	48 (12,68)
Water consumption for combisteaming						
Softened drinking water (l/h (gal/h))	3,5 (0,92)	4,6 (1,22)	4 (1,06)	5,3 (1,4)	8 (2,11)	10,6 (2,8)
Water consumption for WaveClean cleaning program						
Softened drinking water (l (gal))	3 l (0,79)					
Drinking water (l (gal))	32 l (8,45)					
Waste water connection						
Waste water type	Dirty water, maximum 80 °C (176 °F)					
Connection to unit (mm (in))	50 (1,97)					
Maximum length (m (ft))	1 (3,3) with a drop of at least 5 % or 3°					

FM08-454-E

Size	615	621	115	121	215	221
Temperature-resistant to (°C (°F))	95 (203)					
Maximum flow rate (l/min (gal/min))	10 (2,64)					
Exhaust air connection						
Connection to unit (mm (in))	53 (2,09)				73 (2,87)	
Maximum length (m (ft))	2,5 (8,2)					
Temperature-resistant to (°C (°F))	180 (356)					

Fastening to the floor

Absolutely essential for the following unit types	
FGE615	Only in conjunction with base cabinet and underframe
FGE621	
FGE115	
FGE121	
FGE121-621	Only in conjunction with stacking kit
FGE115-621	
FGE121-615	
FGE115-615	

Transformer voltage

Type of connection	3NPE / AC 50/60 Hz, 3PE / AC 50/60 Hz	
Voltage range (V)	208 — 240	
Transformer	T1	
Wire identification or color	blue	red
Voltage measured (V)	Voltage at transformer (V)	
208	0	208
240	0	240

Description of the unit

Basic setting of the control

Basic setting	Parameters	Standard value	Range of adjustment	Explanation
Supply voltage	14	400	100 — 500 V	Enter the local, mean voltage between the line conductors.
Altitude	2	0	0 = 0 — 999 m (3277 ft)	Request the altitude above sea level from the local weather station. If the altitude is unknown, enter 0 — 999 m (3277 ft).
			1 = 1000 m (3280 ft) — 1999 m (6557 ft)	
			2 = 2000 m (6560 ft) — 2499 m (8197 ft)	
			3 = 2500 m (8200 ft) or higher	
Volume of audible signal	33	0	0 = Quiet	Setting the volume
			1 = Loud	
Unit of temperature	1	0	0 = °C	Celsius (°C)
			1 = °F	Fahrenheit (°F)
Unit of volume	34	0	0 = ml	Milliliter (ml)
			1 = fl.oz	Fluid ounce (fl.oz.)
	35	0	0 = Imperial (fl.oz.)	Imperial fluid ounce
			1 = U.S. (fl.oz.)	U.S. fluid ounce
80 % power	3	0	1 = 80 %	Power can be limited to 80 % (for special applications).
			0 = 100 %	
Power optimization system	42	0	1 = On	If a power optimization system is connected, "On" must be selected for the unit to heat.
			0 = Off	

Basic setting of control (Advanced)

Basic setting	Parameter s	Standard value	Range of adjustment	Explanation
Condensation-hood after-running time	5	60	0 – 600 s	Time extension for the condensation hood, after the cooking chamber door has been opened
Generator mode	45	0	0 = No 1 = Yes	When a generator is used to supply electricity
Steam elimination	48	1	0 = Low 1 = Normal 2 = High	Sets the steam elimination level
Duration of audible signal	6	20	0 = Signal off 1 — 180 s	Duration of the audible signal

4 Transporting the unit

⚠ CAUTION

Risk of property damage and personnel injury from tipping unit

- Stay clear of lifted unit.
- Move lifted unit carefully.

NOTICE

Risk of property damage from improper transport

- Transport the unit upright.
- Do not tilt or stack the unit.
- Pay attention to protruding parts when transporting the unpacked unit.

Prior to transporting the unit to the installation site, ensure that:

- The roadway has adequate load-bearing capacity.
- Wall openings are large enough.

4.1 Transporting the unit to the installation site

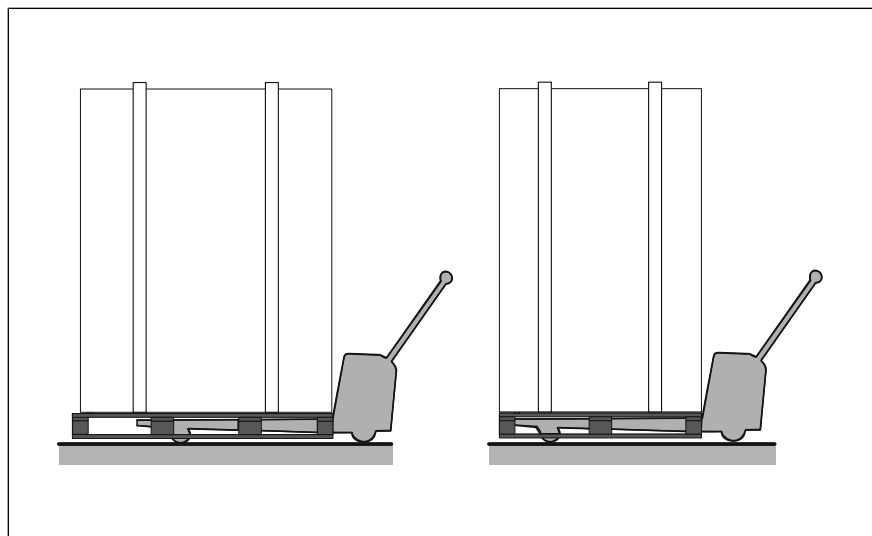

Image: Lengthwise and crosswise transport on pallet

→ Use suitable transport means to move unit to its installation site.

4.2 Unpacking the unit

⚠ CAUTION**Risk of injury from sharp edges**

- Wear protective gloves.
-

INFORMATION

When unpacking the unit, inspect it for transport damage.

Do not install damaged units or put into service.

1. Remove the packaging.
2. Pull the protective film off the unit.
3. Remove all packaging material from the cooking chamber.
4. Clean the unit (See Operating instructions).
5. Enter the information from the nameplate into the Start-up operation report.
6. Enter the information from the nameplate into the Operating instructions.

5 Installing the unit

⚠ WARNING

Risk of burns from spraying hot fat

- Install deep-fat fryers outside the range of the hand shower.

⚠ CAUTION

Risk of crushing from improper installation

- Protect the unit and work area during installation and alignment.

⚠ CAUTION

Risk of fire from failure to observe applicable regional fire prevention regulations

- Observe applicable regional fire prevention regulations.

NOTICE

Risk of property damage from overheating of the unit

- Do not install the unit close to heat sources.

5.1 Minimum clearances

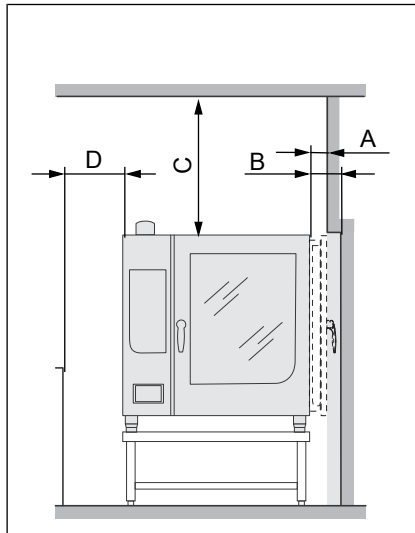

Image: Minimum clearances to walls, ceiling or units

A	B	C *	D **
50 (1,97)	100 (3,94)	---	50 (1,97)
All dimensions in mm (in)			
* Depends on the kitchen ventilation system and quality of ceiling material			
** For service work 500 mm (19,69 in) recommended			

The following clearances from walls, ceilings or other equipment must be maintained when installing the unit:

- Left, right and rear: at least 50 mm (1,97 in).
- For service work 500 mm (19,69 in) on the left is recommended.
- For parking the tray trolley, 800 mm (31,5 in) on the left.
- Clearance from heat sources (baking oven), 500 mm (19,69 in) on the left.
- Clearance to deep-fat fryers, at least one length of the hand shower at left and right.

5.2 Lifting the unit off the pallet

⚠ CAUTION

Risk of property damage and personnel injury from tipping unit

- Stay clear of lifted unit.
- Move lifted unit carefully.

NOTICE

Risk of property damage from lifting the unit incorrectly

- Place the forks of the pallet truck next to the siphon.

Prerequisite Unit unpacked
Protective film removed
Unit cleaned

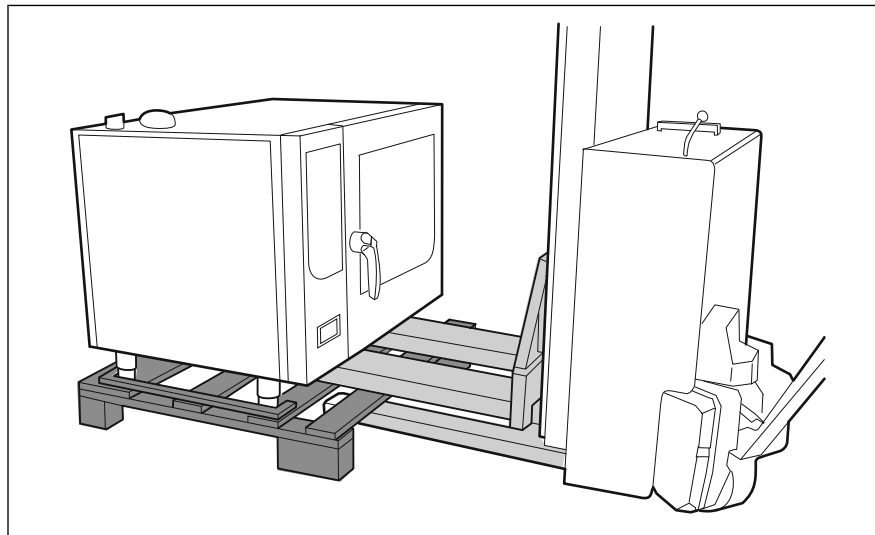

Image: Lifting the unit off the pallet

1. Slide the forks of the pallet truck under the unit and to the right of the siphon.
2. Lift the unit off the pallet.

5.3 Installing the unit on the unit legs

Prerequisite The floor must carry the weight of the unit

1. Lift the unit with the pallet truck.
2. Move the unit to the installation site.
3. Place the unit on the floor.
4. Set up the unit in accordance with the planning drawing (see "Planning drawing").

5.4 Setting up the unit on a base frame

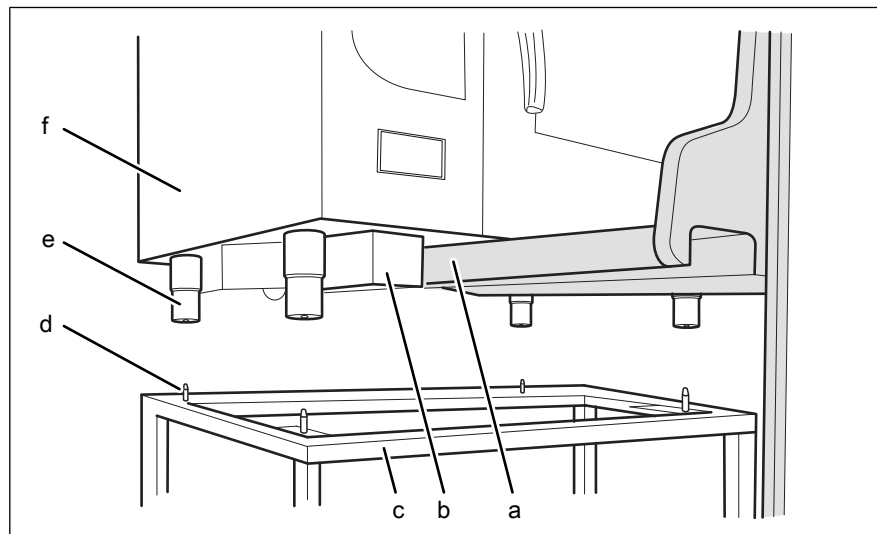

Image: Setting up the unit on a base frame

- | | | | |
|---|------------------------|---|-----------|
| a | Lift fork | d | Stud bolt |
| b | Waste trap on the unit | e | Unit leg |
| c | Base frame | f | Unit |

- Prerequisite** The base frame must carry the weight of the unit
 Base frame levelled
 Base frame must be set up in accordance with the planning drawing
1. Lift the unit.
 2. Place the unit over the stud bolts and onto the base frame.

CAUTION

Risk of scalding due to spillage of hot cooked food

- Attach stickers if the upper insertion rails are higher than 1,6 m (5,3 ft).

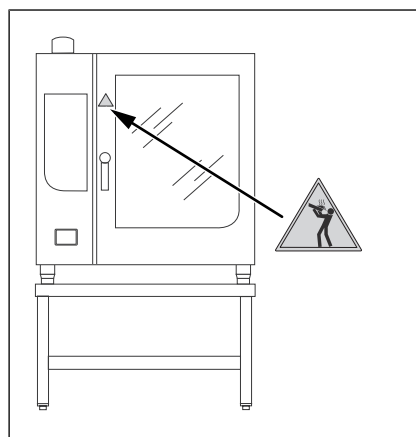

Image: Attach warning sign regarding the shelf height

3. Clean the adhesion surface for the sticker.
4. Attach the sticker to the cooking chamber door at a height of 1,6 m (5,3 ft).

Installing the unit

5.4.1 Installing the support rack

Depending on the version, the base frame can be equipped with a hang-in frame.

The hang-in the frame is used to hold containers, baking sheets and grates.

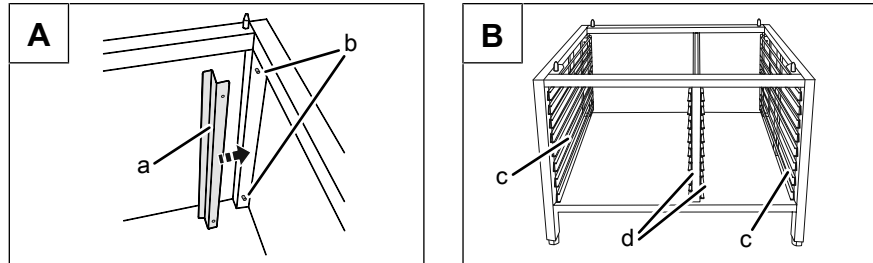

Image: A Stop profile, B Hang-in frame

a Stop profile
b Bolt

c Outboard support rack
d Inboard support rack

Prerequisite Pins installed in the uprights of the base frame

1. Place the stop profiles on the pins (at the back).
2. Install the support racks.

5.5 Aligning the unit

5.5.1 Aligning countertop unit

Prerequisite Base frame levelled

- Level the unit by screwing the equipment legs in or out.
- Fill out the Start-up operation report.

5.5.2 Aligning a floor-standing unit

NOTICE

Risk of water discharge from leaking cooking chamber

The cooking chamber will leak if the tray trolley is not aligned.

- Operate a floor-standing unit only with the tray trolley.
- Align the tray trolley carefully.

INFORMATION

The tray trolley is needed to align a floor-standing unit.

Prepare the tray trolley.

Aligning tray trolley

Prerequisite The floor under and in front of the unit is flat

1. Level the unit by screwing the equipment legs in or out.
2. With poor floor conditions, place spacers on the casters of the tray trolley.
3. Open cooking chamber door.
4. Move tray trolley into the unit until it stops and check the alignment.
5. Close the cooking chamber door.
 - ↳ The sheet metal sealing strip on the tray trolley should make full contact (no gaps) with the door seal.
 - ↳ The shelves in the unit are horizontal.
6. Fill out the Start-up operation report.

Aligning tray trolley with insertion system

The Combisteamer can be equipped with the EasyIn insertion system (optional).

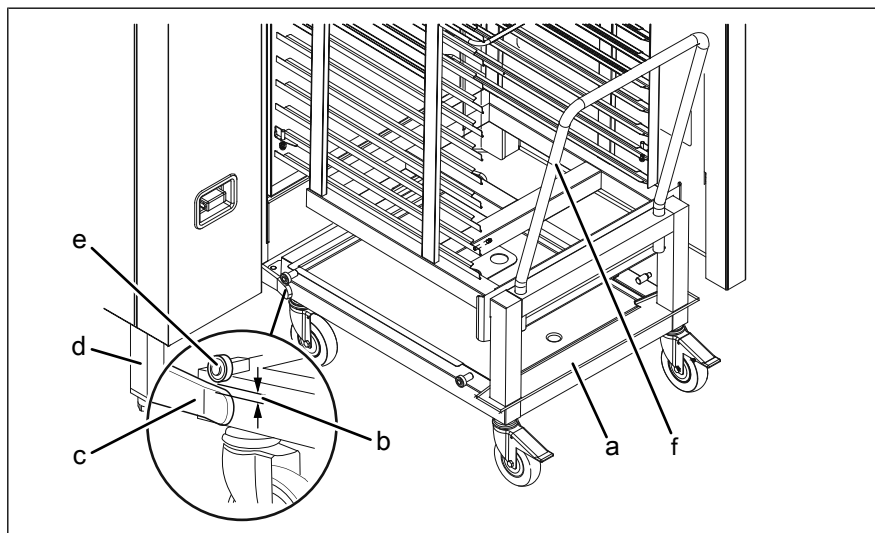

Image: Aligning tray trolley with insertion system

- | | |
|----------------|------------------|
| a Tray trolley | d Unit leg |
| b Distance | e Support roller |
| c Guide rail | f Handle bar |

1. Level the unit by screwing the equipment legs in or out.
2. Open cooking chamber door.
3. Place the tray trolley against the guide rails.
4. Screw the unit legs in or out until the rollers are 1 mm (0,04 in) — 5 mm (0,2 in) over the guide rails.
5. Retract the tray trolley.
6. Level the guide rails.

7. Move tray trolley into the unit until it stops and check the alignment.
↳ The support rollers of the inserted tray trolley no longer have floor contact.
8. Remove the push handle.
9. Close the cooking zone door.
10. Fill out the start-up operation report.

5.6 Fastening the unit to the floor

5.6.1 Securing the unit to prevent tipping

WARNING

Risk of accident from insufficient fastening

Unit can tip over

- Depending on the unit type, suitable measures must be taken to fasten the unit to the floor.
- Comply with the requirements for the condition of the floor.
- Comply with the requirements for the means of fastening.
- Follow the manufacturer's instructions for using the means of fastening.

Depending on the size, it is essential that certain combi-steamer types or combi-steamers used in combination with a Stapelkit (stacking kit), a recirculation hood, an underframe or base cabinet be secured to prevent tipping.

Unit types that must be secured to prevent tipping (see "Unit and connection data").

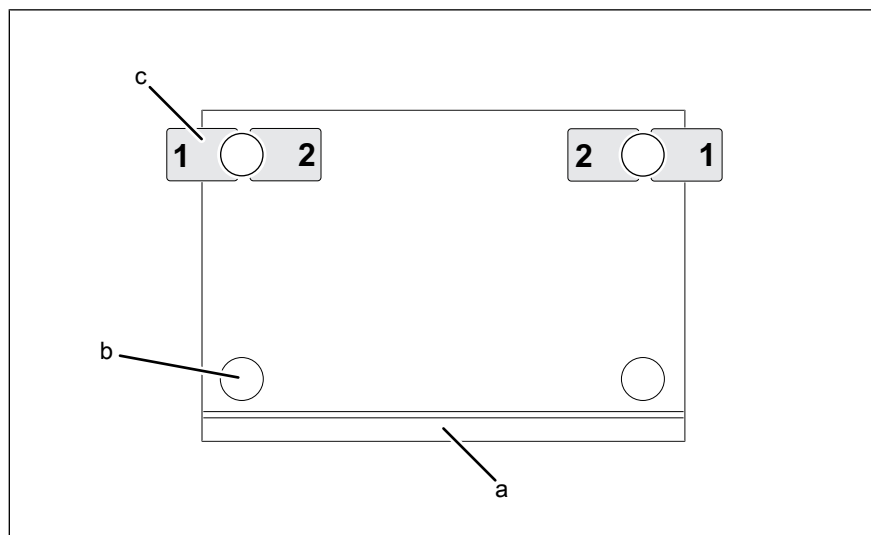

Image: Arrangement of floor plates (view from above)

- a Cooking chamber door
b Unit leg
c Floor plates

A special set of fasteners is either supplied by the manufacturer or available as an accessory to secure the unit against tipping.

The set of fasteners includes two floor fasteners and all components required for bolting or gluing to the floor.

The unit is fastened by means of two floor fasteners, as indicated in the drawing.

Floor without steam barrier

In the case of floors without a steam barrier, the floor plates are bolted to the floor using the bolts provided.

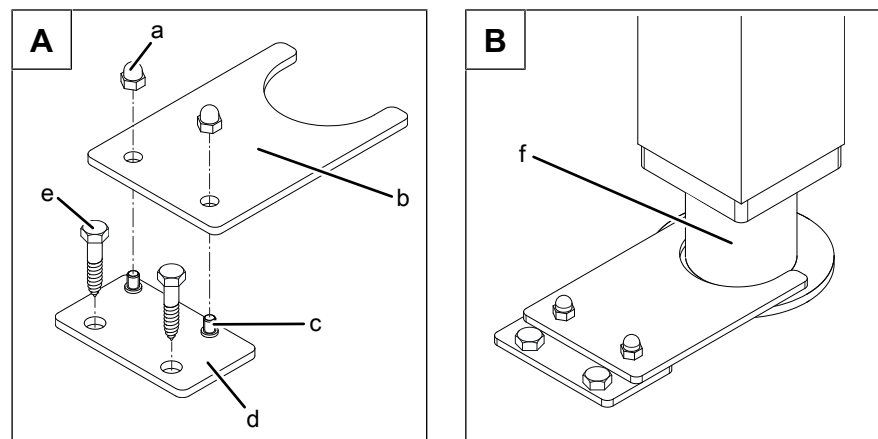

Image: A: Position of floor plate; B: floor plate bolted to the floor

- | | | | |
|---|---------------|---|-------------|
| a | Cap nut | d | Floor plate |
| b | Holding plate | e | Lag bolt |
| c | Upright bolt | f | Unit leg |

Requirements The floor must support the weight of the unit

The floor must be clean and suitable for the manner of fastening

Unit set up and aligned in accordance with the planning drawing

1. Insert the floor plate from the fastener set into the holding plate as shown in the drawing.
2. Screw on the cap nuts hand-tight.
3. Align the floor plates in position 1-1 or 2-2 on the unit leg as shown in the drawing and mark the fastening holes in the floor.
4. Mark the position of all unit legs on the floor.
5. Using appropriate lifting gear, move the unit so that the holes can be drilled in the floor.
6. Drill holes matching the diameter of the anchor sufficiently deep in the floor.
7. Carefully place the unit in the installation position.
8. Screw on the cap nuts and remove the holding plate from the floor plate.
9. Screw the floor plate to the floor using the anchors and bolts supplied.
10. Ensure that sealing of the floor is restored after the bolts are screwed in.

11. Place the holding plate on the floor plate and fasten in place with cap nuts.
12. Fill out the start-up operation report.

Floor with steam barrier

In the case of floors with a steam barrier, the floor plates are not screwed to the floor but fastened with the enclosed adhesive.

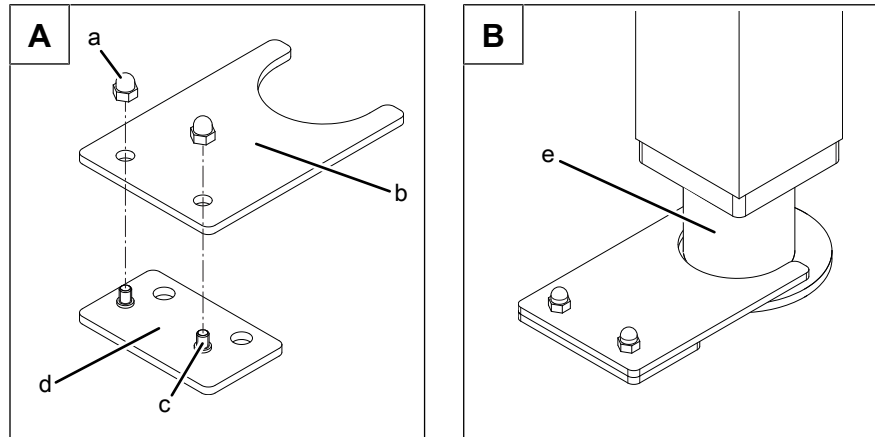

Image: A: Position of floor plate; B: floor plate glued to the floor

- | | | | |
|---|---------------|---|-------------|
| a | Cap nut | d | Floor plate |
| b | Holding plate | e | Unit leg |
| c | Upright bolt | | |

Requirements The floor must support the weight of the unit
The floor must be clean and suitable for the manner of fastening
Unit set up and aligned in accordance with the planning drawing

1. Insert the floor plate from the fastener set into the holding plate as shown in the drawing.
2. Screw on the cap nuts hand-tight.
3. Align the floor fasteners in position 1-1 or 2-2 on the unit leg as shown in the drawing and mark the floor.
4. Screw on the cap nuts and remove the holding plate from the floor plate.
5. Fasten the floor plates to the floor with the enclosed adhesive.
 - ↳ Follow the instructions of the adhesive manufacturer.
 - ↳ Apply the adhesive in accordance with the manufacturer's instructions.
 - ↳ Observe the drying time in the manufacturer's instructions.
6. Place the holding plate on the floor plates and fasten in place with cap nuts.
7. Fill out the start-up operation report.

5.6.2 Securing the unit to prevent slipping

If necessary, the size 2XX combi-steamer can be secured to prevent movement (optional).

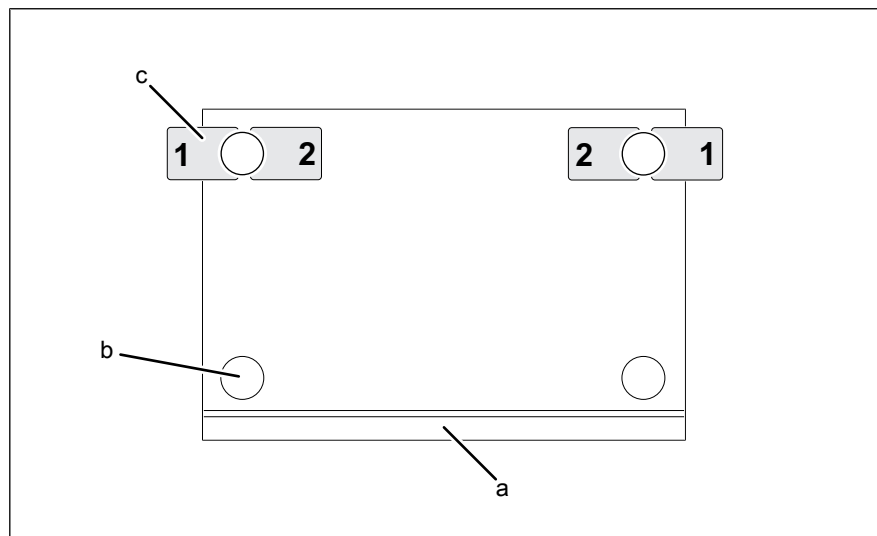

Image: Arrangement of floor plates (view from above)

- | | | | |
|---|----------------------|---|--------------|
| a | Cooking chamber door | c | Floor plates |
| b | Unit leg | | |

A special set of fasteners with locating plates is available from the manufacturer as an accessory to secure the unit against slipping.

The set of fasteners includes two locating plates and all components required for bolting or gluing to the floor.

The unit is fastened by means of two locating plates, as indicated in the drawing.

Floor without steam barrier

In the case of floors without a steam barrier, the floor plates are bolted to the floor using the bolts provided.

Prerequisite The floor must support the weight of the unit

The floor must be clean and suitable for the manner of fastening
Unit set up and aligned in accordance with the planning drawing

1. Align the locating plates in position 1-1 or 2-2 on the unit leg as shown in the drawing and mark the fastening holes in the floor.
2. Mark the position of all unit legs on the floor.
3. Using appropriate lifting gear, move the unit so that the holes can be drilled in the floor.
4. Drill holes matching the diameter of the anchor sufficiently deep in the floor.
5. Carefully place the unit in the installation position.
6. Screw the locating plates to the floor using the anchors and bolts supplied.

7. Ensure that sealing of the floor is restored after the bolts are screwed in.
8. Fill out the start-up operation report.

Floor with steam barrier

In the case of floors with a steam barrier, the floor plates are not screwed to the floor but fastened with the enclosed adhesive.

Prerequisite The floor must support the weight of the unit
The floor must be clean and suitable for the manner of fastening
Unit set up and aligned in accordance with the planning drawing

1. Align the locating plates in position 1-1 or 2-2 on the unit leg as shown in the drawing and mark the floor.
2. Fasten the locating plates to the floor with the enclosed adhesive.
 - ↳ Follow the instructions of the adhesive manufacturer.
 - ↳ Apply the adhesive in accordance with the manufacturer's instructions.
 - ↳ Observe the drying time in the manufacturer's instructions.
3. Fill out the start-up operation report.

6 Connecting the unit

⚠ DANGER

Risk of personal injury and property damage from electric shock

- Before working on the unit, ensure that the unit is dead.
- Do not operate the unit with the housing open.

⚠ CAUTION

Risk of injury from sharp edges

- Wear protective gloves.

NOTICE

Risk of property damage from damage to the lines

- Remove and attach housing components carefully.

6.1 Opening and closing the housing

6.1.1 Removing and attaching the side wall

Removing the side wall

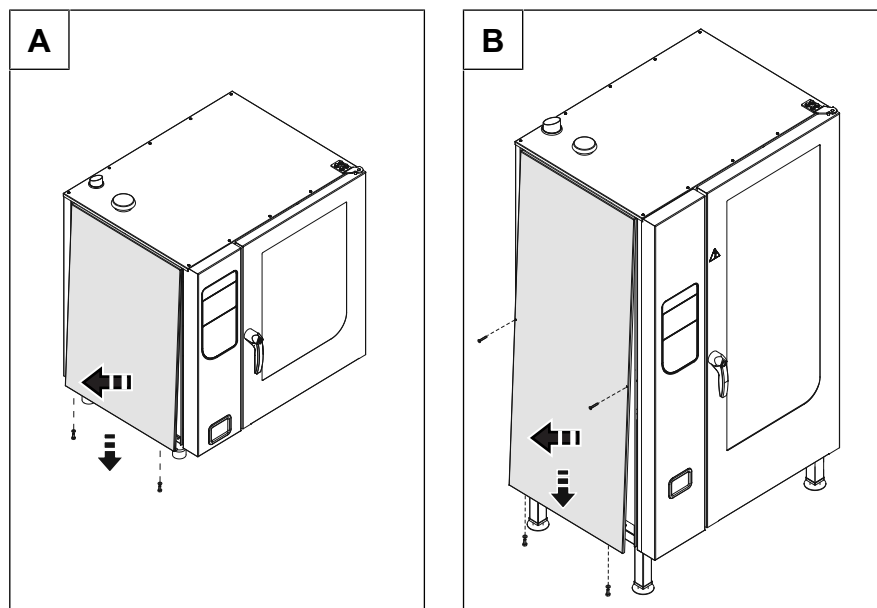

Image: A Sizes 6XX and 1XX; B Size 2XX

1. Unscrew the screws in the side wall.
2. Pull the bottom edge of the side wall forwards.
3. Remove the side wall.

Attaching the side wall

NOTICE

Risk of property damage from leaky housing

- Check seals when attaching the housing parts.
- Replace damaged seals.

1. Insert top edge of side wall.
2. Carefully push the bottom of the side wall inward.
3. Secure the bottom of the side panel with screws.
4. Check that the side wall is in contact with the unit on all sides.

6.2 Making the electrical connection

Electrical installation work

Electrical installation work on the electric system and the unit may only be performed by a specialist company, which is approved by the electric utility company in the particular region. The applicable regional regulations, standards and guidelines must be observed, as well as the connection conditions imposed by the electric utility company responsible.

Technical qualifications for electrical installation tasks

Electrical installation tasks on the electrical system and the unit may be carried out only by an electrician provided by the specialist company contracted.

NOTICE

Risk of property damage from wrong supply voltage

- Prior to connecting, measure the supply voltage and check the voltage set on the transformer inside the unit.

The unit must be connected in accordance with the information on the nameplate and the instructions of this manual.

Wiring diagram

The wiring diagram is included with the unit.

Electrical connection line

Minimum requirements for the unit's electrical connection line to the electrical supply mains:

Connection	Electrical connection line
Permanent connection for fixed installation with a cable from the unit to a separate connection box.	Rubber sheath cable, oil-resistant, shrouded and flexible in accordance with IEC 60245-57 (for example: H05RN-F).
Connection of the unit with a connector.	
Permanent connection for fixed installation with a hard-wired line directly connected to the unit.	PVC sheathed cable for permanent installation in buildings or damp and wet rooms.

FM08-454-E

Permanent connection

⚠ CAUTION

Risk of property damage and personal injury from improper installation

- In the case of a permanent connection, install an all-pin separating device before the unit.

Install an all-pin separating device if the unit will be connected permanently to the electrical supply mains.

Plug-in connection

⚠ CAUTION

Risk of property damage and personal injury from improper installation

- The plug-in connection must be readily accessible.

If the unit is connected with a plug to the electrical supply mains, use plugs and sockets according to IEC60309.

The socket must be readily accessible so that the unit can be disconnected from the electrical supply mains at any time.

Insulation monitoring

In the case of an unearthed network (IT network), the unit can be incorporated into the insulation monitoring.

Fault current device

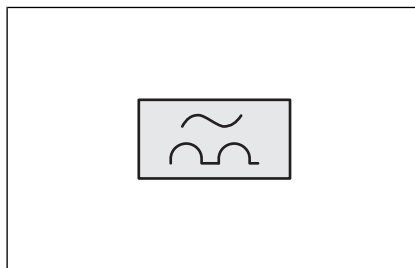

Image: RCD switch type A circuit symbol

The unit can be connected to a fault current device.

If a residual-current circuit breaker is used, the residual-current circuit breaker installed must be type A (RCD type A) to ensure that AC fault currents and pulsating DC fault currents are detected.

The unit generates a small fault current through use of special electronic components. To ensure that the residual current device does not trip during normal operation, each unit should have its own residual current device.

If the unit is connected to electrical supply mains without a neutral conductor, a type B fault current circuit breaker (RCD type B), which is sensitive to all types of current, must be installed.

Potential equalization

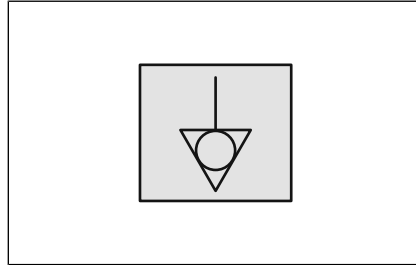

Image: Potential equalization symbol

The unit can be included in a potential equalization system by means of appropriately sized wiring.

6.2.1 Adjusting the unit to the supply voltage

DANGER

Risk of personal injury and property damage from electric shock

- Before working on the unit, ensure that the unit is dead.
 - Do not operate the unit with the housing open.
-

NOTICE

Risk of property damage from wrong supply voltage

- Prior to connecting, measure the supply voltage and check the voltage set on the transformer inside the unit.
-

NOTICE

Risk of property damage from wrong supply voltage

- If the unit is converted from 208 V to 240 V, the power output must be limited to 80 % (see "Basic setting").
-

The unit is set to a specific supply voltage or voltage range when delivered.

If the voltage on site differs from the preset supply voltage, damage may occur.

Prior to connecting the unit, you must measure the supply voltage, check the transformers in the unit and reposition the connections if necessary.

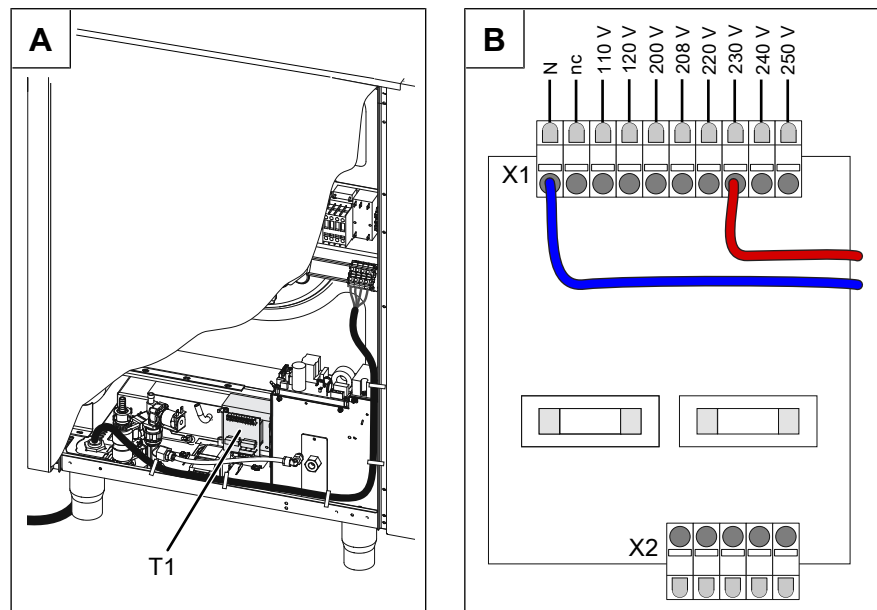

Image: A Transformer T1 location; B Transformer connections for control system

Prerequisite Unit dead
Left side wall removed

1. Use an appropriate meter to measure the supply voltage.
 - ↳ The voltage range must match the information on the nameplate.
 - ↳ If voltage fluctuations are to be expected, take the maximum expected voltage into account.
2. Check whether the transformer voltage is within the specified range (see "Unit and connection data").
 - ↳ If the set voltage differs, reposition the connections for the transformer voltage.
 - ↳ Document the new voltage that was set on the sticker.
3. In units with several transformer, repeat the procedure for each transformer.
4. Close the housing (see "Opening and closing the housing").
5. Fill out the Start-up operation report.

6.2.2 Connecting the electrical connection line

⚠ DANGER

Risk of personal injury and property damage from electric shock

- Before working on the unit, ensure that the unit is dead.
- Do not operate the unit with the housing open.

⚠ DANGER

Risk of personal injury and property damage from electric shock

- Before connecting, ensure that the electrical connection line is dead.
- Ensure that the electrical connection line is undamaged.

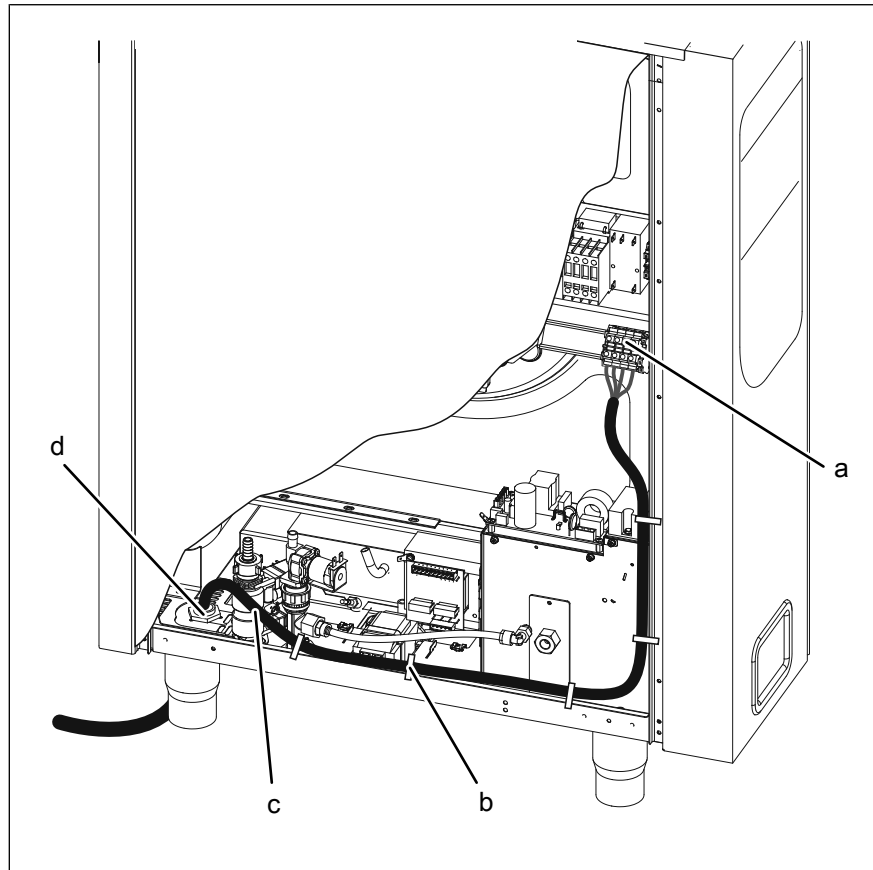

Image: Connecting the electrical connection line

- | | | | |
|---|----------------------|---|----------------------------|
| a | Connection terminals | c | Electrical connection line |
| b | Cable ties | d | Threaded cable connection |

Prerequisite Unit dead
Electrical connection line dead
Unit adjusted to supply voltage
Side wall open

1. Feed the electrical connection line into the unit through the threaded cable connection.
2. Connect the power connection cable in accordance with the wiring diagram.
3. Secure the electrical connection line with cable ties.
4. Tighten the threaded cable connection securely to provide strain relief.
5. Close the housing (see "Opening and closing the housing").
6. Fill out the Start-up operation report.

6.2.3 Connecting the power optimization system

⚠ DANGER

Risk of personal injury and property damage from electric shock

- Before working on the unit, ensure that the unit is dead.
- Do not operate the unit with the housing open.

⚠ DANGER**Risk of personal injury and property damage from electric shock**

- Before connecting, ensure that the electrical connection line is dead.
- Ensure that the electrical connection line is undamaged.

The unit can be connected to a power optimization system.

Prerequisite Unit dead

Electrical connection line dead

Housing opened

1. Pull the electrical connection line into the unit through the cable gland.
2. Route the electrical connection line to the connection terminals.
3. Connect the electrical connection line in accordance with the wiring diagram.
4. Secure the electrical connection line with cable ties.
5. Register the power optimization system in the basic settings of the control (see "Making the basic settings of the control").
6. Fill out the Start-up operation report.

6.2.4 Connecting the potential equalization

Image: Connecting the potential equalization

1. Route and connect the potential equalization line to the marked connection.
2. Fill out the Start-up operation report.

6.3 Performing the basic setting of the control

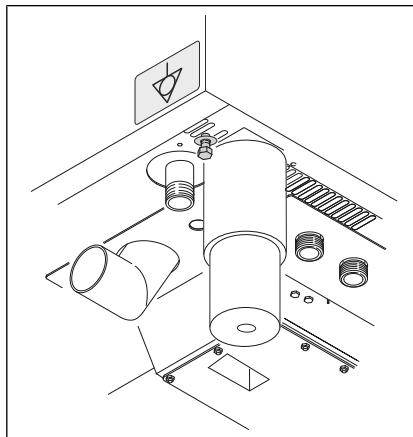
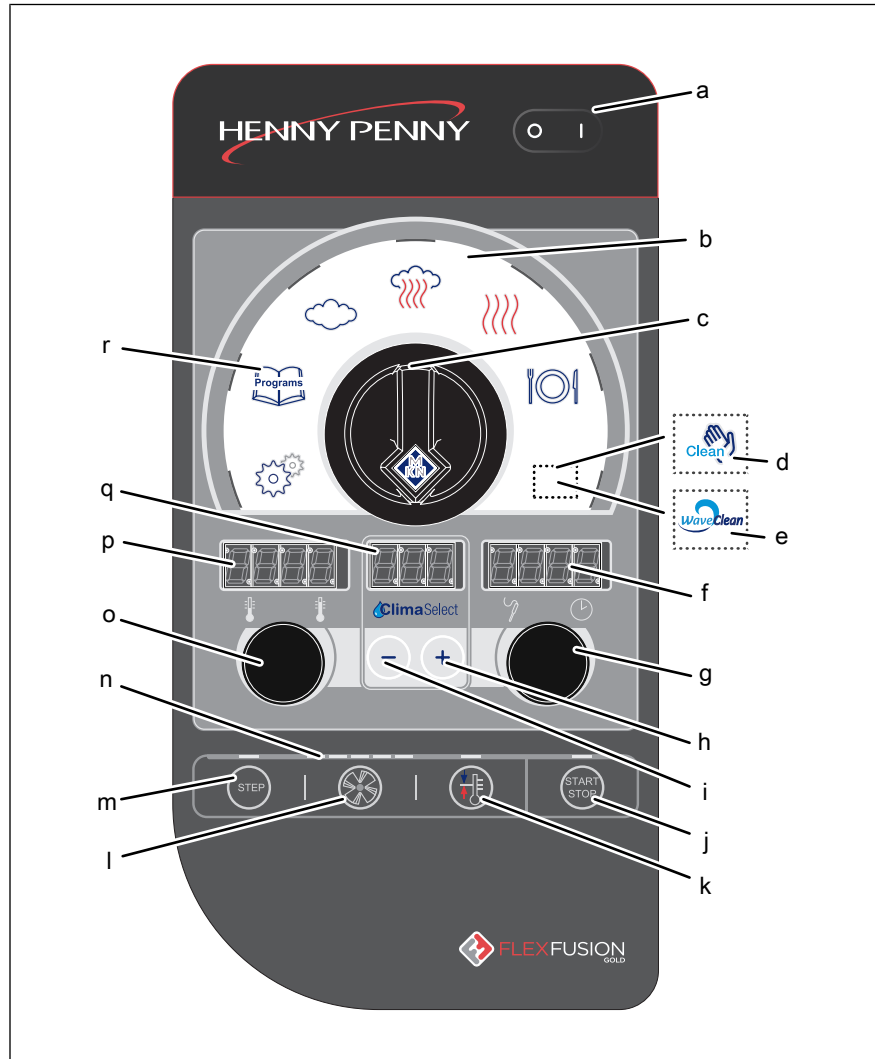

- a On Off "I O" button
- b Selection range
- c Select knob
- d HandClean symbol
- e WaveClean symbol
- f Right display
- g Right knob
- h Plus button
- i Minus button
- j "START STOP" button
- k Ready2Cook button
- l Fan speed button
- m "STEP" button
- n Indicator light
- o Left knob
- p Left display
- q Middle display
- r "Programs" button

6.3.1 Opening the Setting menu

By entering the password "2100", the basic setting for the installation can be displayed and changed.

Prerequisite The unit is on

1. Turn the *Select* knob to the *Settings* symbol.
 - ↳ The indicator light illuminates.
 - ↳ The left display shows "PASS".
 - ↳ The right display flashes "- - - -".
2. Use the right not to set the password.
 - ↳ The right display shows the set password.
3. Press the "START STOP" button.
 - ↳ Use the left knob to select "OPt".
4. Press the "STEP" button to leave the Settings menu.
 - ↳ The basic settings can be changed.

6.3.2 Changing the basic setting of the control

1. Press the "START STOP" button.
 - ↳ Left display flashes the basic setting parameter (see "Unit and connection data").
 - ↳ "OPt" appears on the centre display.
 - ↳ The right display shows the first set value.
2. Turn the left knob.
 - ↳ Set number.
3. Press the "START STOP" button.
 - ↳ The basic setting can be adjusted.
4. Turn the right rotary knob.
 - ↳ Set new value.
5. Press the "START STOP" button.
 - ↳ Accept changes.
6. Press the "STEP" button twice to leave the Settings menu without changes.
7. Press and hold the "STEP" button for 3 seconds.
 - ↳ Changes are saved.
 - ↳ "OPt" flashes on the left display.
 - ↳ The centre display shows "Stor".
 - ↳ The unit restarts.
8. Fill out the start-up operation report.

6.4 Making the water connection

Drinking water installation tasks

Drinking water installation tasks on drinking water lines and the unit may only be performed by a specialist company, which is approved by the drinking water utility company in the particular region. The applicable regional regulations, standards and guidelines must be observed, as well as the connection conditions imposed by the drinking water utility company responsible.

Technical qualifications for drinking water installation tasks

Drinking water installation tasks on drinking water lines and the unit may be carried out only by a water specialist provided by the specialist company contracted.

The unit has a connection for permanent installation to the drinking water supply.

The unit is equipped with a permanent connection for:

- Softened drinking water for steam generation
- Drinking water for cooling, rinsing and cleaning

CAUTION

Hygiene risk from contaminated drinking water

- The connection to the drinking water supply must be equipped with a back-flow preventer.

NOTICE

Risk of property damage from the wrong water quality

- Ensure that the water quality complies with the unit and connection data.

INFORMATION

Always connect both water connections to the unit.

6.4.1 Connecting the drinking water connection line

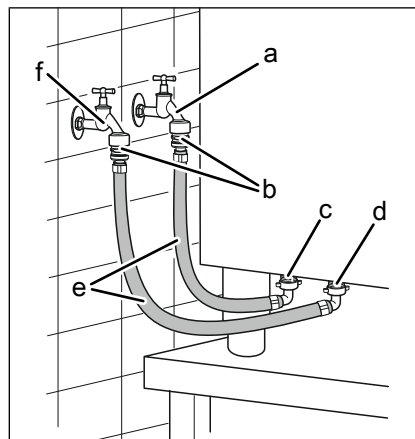

Image: Water connection

- | | | | |
|---|------------------------------------|---|---------------------------|
| a | Softened drinking water | d | Drinking water connection |
| b | Backflow preventer | e | Tap water connection line |
| c | Softened drinking water connection | f | Drinking water |

Prerequisite Water pressure complies with specifications (see "Unit and connection data")
 Backflow preventer installed
 Pressure-resistant connection lines suitable for tap water are available

1. Connect the connection lines to the drinking water taps using seals.
2. Flush the connection lines thoroughly.
3. Insert dirt filters into the water connections on the unit.
4. Connect the drinking water connection line to the unit.
5. Connect the connection line for softened drinking water to the unit.
6. Open the tap water valves and check the threaded connectors for leaks.
7. Fill out the Start-up operation report.

6.4.2 Connecting softened drinking water to both connections

If only softened drinking water is available at the installation site, use a T-piece to connect both water connections on the unit to each other.

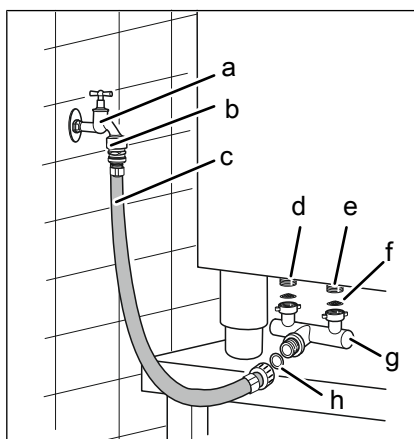

Image: Connecting softened drinking water to both connections

- | | |
|--------------------------------------|-----------------------------|
| a Softened drinking water | e Drinking water connection |
| b Backflow preventer | f Dirt filter |
| c Connection line | g T-piece |
| d Softened drinking water connection | h Seal |

Prerequisite Water pressure complies with specifications (see "Unit and connection data")
 Backflow preventer installed
 Pressure-tight connection line suitable for drinking water is available

1. Connect the connection line to the tap for softened drinking water using a seal.
2. Flush the connection line thoroughly.
3. Insert dirt filters into the water connections on the unit.

4. Connect T-piece to the unit.
5. Connect the connection line for softened drinking water to the T-piece using a seal.
6. Open the drinking water tap and check the threaded fittings for leakage tightness.
7. Fill out the Start-up operation report.

6.5 Making the waste water connection

Waste water installation tasks



Waste water installation tasks on waste water systems and the unit may only be carried out by a specialized company that is responsible for waste water systems. The applicable regional regulations, standards and guidelines must be observed, as well as the connection conditions imposed by the operator of the waste water company responsible.

Technical qualifications for waste water installation tasks

Waste water installation tasks on waste water lines and the unit may be carried out only by a waste water specialist provided by the specialist company contracted.

6.5.1 Determining the type of connection to the sewer system

The units can be equipped with either an automatic or manual cleaning system. The symbol on the control unit indicates which cleaning system is installed.

Cleaning system	Type of connection to the sewer system
 Automatic cleaning system	Permanent connection , with on-site waste trap: Install a vacuum breaker in the waste water line.
 Manual cleaning system	Unobstructed discharge with funnel waste trap: With an on-site waste trap, connect only discharge funnel.

6.5.2 Connecting the waste water line to a permanent connection

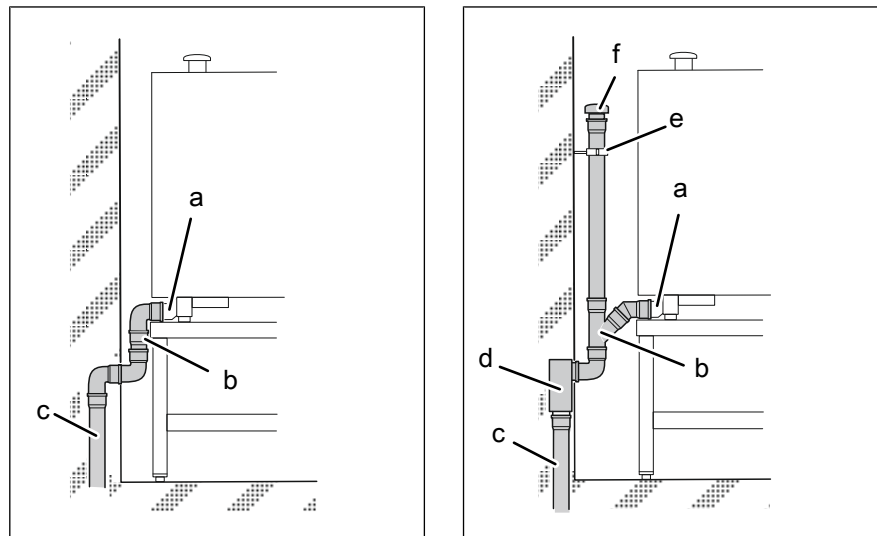

Image: Waste water line to a permanent connection

- | | | | |
|---|------------------------|---|----------------|
| a | Waste water connection | d | Siphon |
| b | Waste water line | e | Pipe clamp |
| c | Waste water mains | f | Vacuum breaker |

INFORMATION

If a siphon is installed in the waste water system, a vacuum breaker must be installed in the waste water line.

Prerequisite The waste water line complies with the specifications (see "Unit and connection data")

1. Install waste water line up to connection to the waste water system.
2. Secure waste water line with pipe clamps.
3. Fill the siphon of the unit with drinking water.
4. Fill out the Start-up operation report.

6.5.3 Connecting a waste water line with an unobstructed discharge

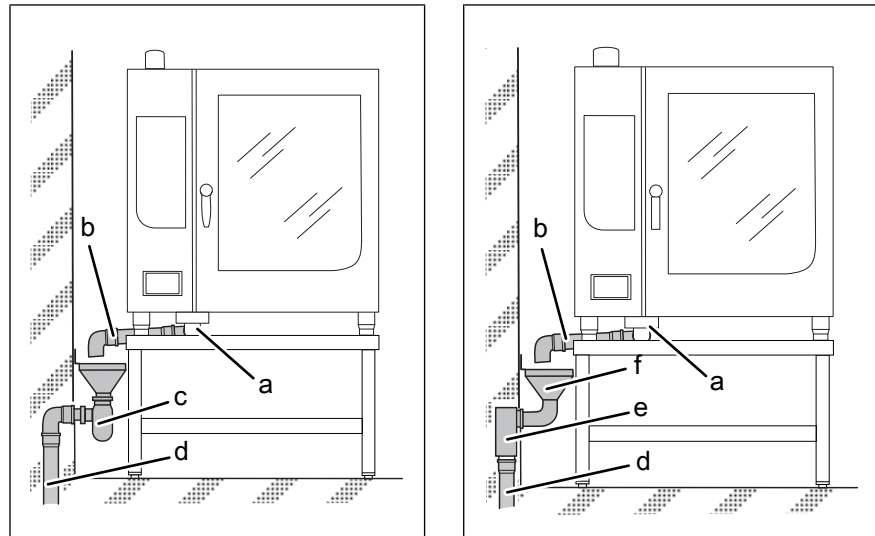

Image: Connecting a waste water line with an unobstructed discharge

- | | |
|--------------------------|-----------------------------|
| a Waste water connection | d Waste water system |
| b Waste water line | e Waste water system siphon |
| c Funnel waste trap | f Discharge funnel |

INFORMATION

Connect only the discharge funnel if a waste water trap is installed in the waste water system.

Prerequisite The waste water line complies with the specifications (see "Unit and connection data")

1. Connect the discharge funnel with waste trap to the sewer system.
2. Connect the waste water line to the unit and extend it to the discharge funnel.
3. Secure waste water line with pipe clamps.
4. Install outlet of the waste water line 20 mm above the discharge funnel.
5. Fill the discharge funnel with tap water.
6. Fill out the Start-up operation report.

6.6 Making the exhaust air connection

When installing the unit under a ventilation system, observe the regional regulations for air conditioning systems.

NOTICE

Risk of property damage from fouling of the outgoing air ducts

- Not connect the exhaust airline directly to the ventilation system.

NOTICE

Risk of corrosion damage from condensate

- Install the exhaust air line such that condensate cannot collect.

6.6.1 Connecting the exhaust air line

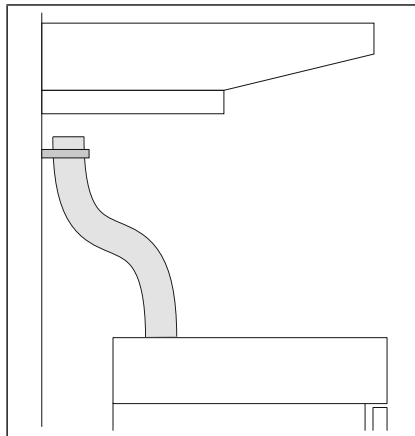

Image: Connecting the exhaust air line

Prerequisite The exhaust air line complies with the specifications (see "Unit and connection data")

1. Connect the exhaust air line to the steam outlet nozzle.
2. Route exhaust air line to the ventilation system with a 3° rise.
3. Fasten the end of the exhaust air line 50 mm (1,97 in) — 200 mm (7,87 in) underneath the ventilation system.
4. Fill out the Start-up operation report.

7 Testing the function

DANGER

Risk of personal injury and property damage from unsuccessful operational check

- Do not put the unit into service.
- Contact customer service.

Prerequisite Electrical connection made
Water connection made
Waste water connection made
Unit cleaned

7.1 Checking the controls

1. Switch on the unit and start any cooking program (see operating instructions).
 - ↳ Set the cooking chamber temperature to a higher temperature than the current cooking chamber temperature.
 - ↳ The unit heats up.
 - ↳ Once the set temperature is reached, heating switches off.
 - ↳ The temperature no longer increases.
 - ↳ The controls are functioning.
2. Switch off the unit.
3. Fill out the Start-up operation report.

7.2 Checking the inspection of the cooking chamber door

1. Switch on the unit and start any cooking program (see operating instructions).
 - ↳ The unit heats up.
 - ↳ The fan is turning.
2. Open the cooking chamber door during operation.
 - ↳ The unit shuts off the heating function.
 - ↳ The fan comes to a stop.
 - ↳ The monitoring of the cooking chamber door is functioning.
3. Close the cooking chamber door.
4. Switch off the unit.
5. Fill out the Start-up operation report.

7.3 Heating and rinsing the unit

1. Switch on the unit.
2. Tap the "Manual cooking" button.
 - ↳ The Manual cooking menu is displayed.
3. Run the unit in the Steaming mode for 15 minutes at 100 °C (212 °F).
4. Rinse the cooking chamber thoroughly with clear water.
5. Run the unit in the hot air mode for 5 minutes at 180 °C (356 °F).
6. Open the cooking chamber door and leave it ajar until the unit is used again.
7. Fill out the start-up operation report.

8 Putting the unit into service

INFORMATION

If the unit is not put into service immediately after being connected and the function check, all inspections must be repeated.

- Prerequisite**
- Electrical connection made
 - Water connection made
 - Wastewater connection made
 - Exhaust air connection made (if required by the customer)
 - Function checked successfully
 - Housing closed
1. Instruct operator.
 2. Fill out the Start-up operation report.

8.1 Nameplate

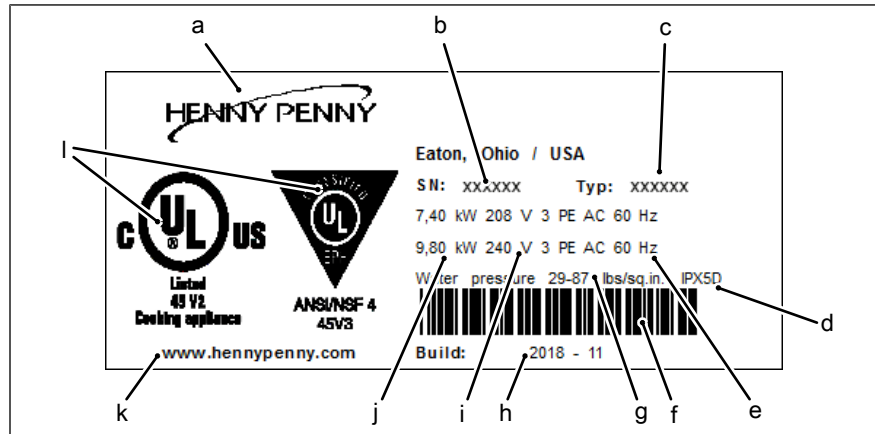

Image: Nameplate information

- a Manufacturer
- b Serial number
- c Type number
- d Protection class
- e Frequency
- f Barcode
- g Connection pressure for water
- h Year of manufacture
- i Type of connection
- j Electrical connected load
- k Manufacturer's web address
- l Certificate

8.2 Filling out the Start-up operation report

General information		Yes	No
Information from the nameplate entered? SN: _____ Typ: _____ E: _____ Bez: _____ Item-Nr.: _____ (if listed)		<input type="checkbox"/>	<input type="checkbox"/>
Obvious damage to the unit? What and where?: _____		<input type="checkbox"/>	<input type="checkbox"/>
Unit levelled?		<input type="checkbox"/>	<input type="checkbox"/>

General information		Yes	No
Unit fastened to floor?		<input type="checkbox"/>	<input type="checkbox"/>
secured against tipping <input type="checkbox"/> Screwed to floor <input type="checkbox"/> Glued to floor	secured against shifting <input type="checkbox"/> Screwed to floor <input type="checkbox"/> Glued to floor		

Electrical connection		Yes	No
Electrical connection made properly?		<input type="checkbox"/>	<input type="checkbox"/>
<input type="checkbox"/> Potential equalization	<input type="checkbox"/> Power optimization system		
<input type="checkbox"/> Potential-free contact	<input type="checkbox"/> _____		
Electrical connections made properly?		<input type="checkbox"/>	<input type="checkbox"/>
Fault current device connected directly before this unit?		<input type="checkbox"/>	<input type="checkbox"/>
Fault current device connected before this and other units?		<input type="checkbox"/>	<input type="checkbox"/>
Supply voltage measured? Supply voltage: _____ (V)		<input type="checkbox"/>	<input type="checkbox"/>
Set transformer voltage T1: blue 0 V red _____ V			

Basic setting of the control		Yes	No
Temperature unit set?		<input type="checkbox"/>	<input type="checkbox"/>
<input type="checkbox"/> °C	<input type="checkbox"/> °F		
Software version identified?		<input type="checkbox"/>	<input type="checkbox"/>
Version: _____			
Altitude set?		<input type="checkbox"/>	<input type="checkbox"/>
<input type="checkbox"/> 0 — 999 m (3277 ft)	<input type="checkbox"/> 1000 m (3280 ft) — 1999 m (6557 ft)		
<input type="checkbox"/> 2000 m (6560 ft) — 2499 m (8197 ft)	<input type="checkbox"/> 2500 m (8200 ft) or higher		

FM08-454-E

Putting the unit into service

Basic setting of the control		Yes	No
80% power set?		<input type="checkbox"/>	<input type="checkbox"/>
<input type="checkbox"/> 100 %	<input type="checkbox"/> 80 %		
Supply voltage set?		<input type="checkbox"/>	<input type="checkbox"/>
Voltage: _____ V			
Audible signal volume set?		<input type="checkbox"/>	<input type="checkbox"/>
<input type="checkbox"/> Low	<input type="checkbox"/> High		
Volume unit set?		<input type="checkbox"/>	<input type="checkbox"/>
<input type="checkbox"/> ml	<input type="checkbox"/> fl.oz. (Imperial)		
<input type="checkbox"/> fl.oz. (U.S.)			
Power optimization system set?		<input type="checkbox"/>	<input type="checkbox"/>
<input type="checkbox"/> On	<input type="checkbox"/> Off		
Water connection		Yes	No
Connection pressure within indicated range?		<input type="checkbox"/>	<input type="checkbox"/>
Connection pressure: _____ (_____) kPa (psi)			
Water connection made properly?		<input type="checkbox"/>	<input type="checkbox"/>
Lines and connections leak-tight?		<input type="checkbox"/>	<input type="checkbox"/>
Water connections connected with T-piece?		<input type="checkbox"/>	<input type="checkbox"/>
<input type="checkbox"/> Connected only to softened drinking water	<input type="checkbox"/> Connected only to drinking water		
Waste water connection		Yes	No
Waste water connection made in a technically correct manner?		<input type="checkbox"/>	<input type="checkbox"/>
<input type="checkbox"/> Siphon in the building	<input type="checkbox"/> Vacuum breaker		
<input type="checkbox"/> Funnel drain	<input type="checkbox"/> Floor drainage channel		
Connection size of waste water line: _____ mm (in)			
Exhaust air connection		Yes	No
Installation under ventilation system?		<input type="checkbox"/>	<input type="checkbox"/>
Connected to outgoing air duct?		<input type="checkbox"/>	<input type="checkbox"/>
Connection size of exhaust air line: _____ mm (in)			
Length of exhaust air line: _____ mm (in)			
Function check		Yes	No
Controls functioning?		<input type="checkbox"/>	<input type="checkbox"/>
Monitoring of cooking chamber door functioning?		<input type="checkbox"/>	<input type="checkbox"/>
Unit heated and rinsed?		<input type="checkbox"/>	<input type="checkbox"/>

Final notes	Yes	No
Was the unit put into service?	<input type="checkbox"/>	<input type="checkbox"/>
Comments:		
Operator trained?	<input type="checkbox"/>	<input type="checkbox"/>

Electrical installation was made by:			
			Signature
Company	Installation fitter	Place, date	

Water installation was made by:			
			Signature
Company	Installation fitter	Place, date	

Wastewater installation was made by:			
			Signature
Company	Installation fitter	Place, date	

Exhaust air connection was made by:			
			Signature
Company	Installation fitter	Place, date	

Function check was made by:			
			Signature
Company	Installation fitter	Place, date	

Operator was trained by:			
			Signature
Company	Installation fitter	Place, date	



Henny Penny Corporation
P.O.Box 60
Eaton, OH 45320
USA

Phone +1 937 456-8400
Fax +1 937 456-8402

Toll free in USA
Phone +1 937 417-8417
Fax +1 937 417-8434

