



Read the operating instructions prior to commissioning

# FlexFusion® ELECTRIC SPACE\$AVER (PLUS)



## Installation manual

### Model

FSEN610

FSEN605



Henny Penny Corporation  
P.O.Box 60  
Eaton, OH 45320  
USA

Phone +1 937 456-8400  
Fax +1 937 456-8402

Toll free in USA  
Phone +1 937 417-8417  
Fax +1 937 417-8434

[www.hennypenny.com](http://www.hennypenny.com)

<b>1 Introduction</b> .....	<b>5</b>
<b>1.1 About this manual</b> .....	<b>5</b>
1.1.1 Explanation of signs .....	6
<b>1.2 Personnel qualifications</b> .....	<b>7</b>
<b>1.3 Use of the unit</b> .....	<b>7</b>
<b>1.4 Warranty</b> .....	<b>7</b>
<b>2 Safety instructions</b> .....	<b>8</b>
<b>3 Description of the unit</b> .....	<b>10</b>
<b>3.1 Overview of the unit</b> .....	<b>10</b>
3.1.1 Tabletop unit .....	10
3.1.2 Built-in unit .....	11
<b>3.2 Unit and connection data</b> .....	<b>11</b>
<b>4 Transporting the unit</b> .....	<b>16</b>
<b>4.1 Transporting the unit to the installation site</b> .....	<b>16</b>
<b>4.2 Unpacking the unit</b> .....	<b>16</b>
<b>5 Installing the unit</b> .....	<b>18</b>
<b>5.1 Minimum clearances</b> .....	<b>18</b>
<b>5.2 Setting up the unit on a work surface or underframe</b> .....	<b>19</b>
5.2.1 Attaching the insertion height warning note .....	19
5.2.2 Installing the hang-in frame .....	19
<b>5.3 Fastening the unit to the floor</b> .....	<b>20</b>
5.3.1 Securing the unit to prevent tipping .....	20
<b>6 Connecting the unit</b> .....	<b>24</b>
<b>6.1 Opening and closing the housing</b> .....	<b>24</b>
6.1.1 Removing and attaching the rear panel .....	24
6.1.2 Removing and attaching the unit cover .....	25
<b>6.2 Making the electrical connection</b> .....	<b>26</b>
6.2.1 Connecting the electrical connection line .....	28
6.2.2 Connecting the power optimization system .....	30
6.2.3 Connecting the potential equalization .....	31
<b>6.3 Connecting the kitchen guiding system</b> .....	<b>31</b>
<b>6.4 Performing the basic setting of the control</b> .....	<b>32</b>
6.4.1 Changing the basic setting of the control .....	32
<b>6.5 Making the water connection</b> .....	<b>33</b>
6.5.1 Connecting the drinking water connection line .....	34
6.5.2 Connecting softened drinking water to both connections .....	34
<b>6.6 Making the waste water connection</b> .....	<b>35</b>
6.6.1 Connecting the waste water line to a permanent connection .....	36
6.6.2 Connecting a waste water line with an unobstructed discharge .....	36
<b>7 Installing the unit</b> .....	<b>38</b>

<b>8 Testing the function .....</b>	<b>39</b>
<b>8.1 Checking the controls .....</b>	<b>39</b>
<b>8.2 Checking the inspection of the cooking chamber door .....</b>	<b>39</b>
<b>8.3 Heating and rinsing the unit .....</b>	<b>39</b>
<b>9 Putting the unit into service .....</b>	<b>41</b>
<b>9.1 Nameplate .....</b>	<b>41</b>
<b>9.2 Filling out the Start-up operation report .....</b>	<b>41</b>

---

# 1 Introduction

## 1.1 About this manual

The installation instructions are part of the unit and contain information on safe installation of the unit.

Observe the following notes and adhere to them:

- Read the installation instructions completely prior to installation.
- Make the installation instructions available to the installation fitter at the operating site at all times.
- Preserve the installation instructions throughout the service life of the unit.
- Insert any additions from the manufacturer.
- Pass on the installation instructions to any subsequent operator of the unit.

**Target group** The target group of the installation instructions is trained qualified personnel that is familiar with installing and operating the unit.

**Figures** All figures in this manual are intended as examples. Discrepancies can arise between this and the actual unit.

### 1.1.1 Explanation of signs

 **DANGER**

#### Imminent danger

Failure to comply will lead to death or very severe injuries.

---

 **WARNING**

#### Potential danger

Failure to comply can lead to death or very severe injuries.

---

 **CAUTION**

#### Dangerous situation

Failure to comply can lead do slight to moderately severe injuries.

---

**NOTICE**

#### Property damage

Failure to comply can cause property damage.

---

**INFORMATION**

#### Information

Notes for better understanding and operation of the unit.

---

Symbol / sign	Meaning
•	Listing of information.
→	Action steps which can be performed in any sequence.
1. 2.	Action steps which must be performed in the specified sequence.
↳	Result of an action performed or additional information relating to it.

## 1.2 Personnel qualifications

### Explanation of qualification

Skilled personnel	<ul style="list-style-type: none"> <li>• A skilled person is someone who, on the basis of their technical training, knowledge and experience as well as familiarity with the applicable standards, can assess the assigned work and recognize possible dangers.</li> </ul>
-------------------	--

Type of activity	Qualification
Electrical connection	<ul style="list-style-type: none"> <li>• Electrician</li> <li>• Specialized training</li> <li>• Employee of the responsible technical company</li> </ul>
Water connection	<ul style="list-style-type: none"> <li>• Water specialist</li> <li>• Specialized training</li> <li>• Employee of the responsible technical company</li> </ul>
Waste water connection	<ul style="list-style-type: none"> <li>• Waste water specialist</li> <li>• Specialized training</li> <li>• Employee of the responsible technical company</li> </ul>

## 1.3 Use of the unit

This unit is intended to be used solely for commercial purposes, particularly in commercial kitchens.

## 1.4 Warranty

The warranty is void and safety is no longer assured in the event of:

- Improper conversion or technical modifications of the unit,
- Improper use,
- Improper startup, operation or maintenance of the unit,
- Problems resulting from failure to observe these instructions.

## 2 Safety instructions

The unit complies with applicable safety standards. Residual risks associated with operation or risks resulting from incorrect operation cannot be ruled out and are mentioned specifically in the safety instructions and warnings.

The installation fitter must be familiar with regional regulations and observe them.

The installation fitter must observe the safety instructions in these installation instructions and in the "Safety information" chapter of the operating instructions.

**Ensuring conformity with standards** Observe applicable international, European and national laws, regulations, standards and directives for the unit when transporting, setting up and connecting it.

**Improper installation Risk of property damage and personal injury from improper installation**

- Install the unit only as specified in these installation instructions.
- Do not add anything to the unit or modify the unit.
- Use only original spare parts.

**Transportation and storage Risk of personal injury and property damage from improper transportation and improper storage**

- Store the unit in a dry, frost-free environment.
- Observe the safety regulations for the lifting gear used.
- Attach the unit to the lifting gear securely during transport and installation, and prevent it from dropping.
- Transport the unit in an upright position, do not tilt or stack.
- Pay attention to protruding parts when transporting the unit without packaging.

**Fire prevention Risk of fire from combustible surfaces**

- Observe general fire prevention regulations.

**Organizational measures Risk of property damage and personal injury from lack of organizational measures**

- Identify danger zones when transporting, installing and connecting the unit.
- Prior to starting the installation tasks, notify any operator present about the procedure.
- Prior to starting the installation task, discuss how to behave in an emergency.
- Use equipment and protective gear suitable for the activity.
- Brace housing components to prevent them from falling over and dropping.



**Installation Risk of property damage and personal injury from improper installation**

- Wear safety shoes and protective gloves.

**Electrical connection Risk of fire from improper connection**

- Observe applicable regional regulations of the electric supplier.
- Ensure that only electricians licensed by the electric supplier connect the unit.
- Ensure that the electrical system is earthed by a protective earthing conductor.
- Note the information on the nameplate.

**Danger of electric shock from live components.**

- Prior to working on the electrical system, switch off the unit, disconnect the electrical system from the mains and prevent power from being switched on again. Check to ensure the system is dead.
- Use only insulated tools.

**Unit on casters Danger of a line breaking if subjected to high tensile load**

- Using a chain to provide strain relief for the connection lines, secure the unit at the installation site so that the connection lines are not put under tension when the unit is moved. The strain relief must be designed for a tensile load of at least 0.6 kN.

**Commissioning Risk of property damage and personal injury from improper commissioning**

- Read the operating instructions prior to commissioning. Observe the safety instructions in these installation instructions and in the "Safety information" chapter of the operating instructions.
- Only put the unit into service after a successful function test in its assembled state.
- Put the unit into service only after it has reached room temperature.
- Observe the units during operation.

## 3 Description of the unit

### 3.1 Overview of the unit

#### 3.1.1 Tabletop unit

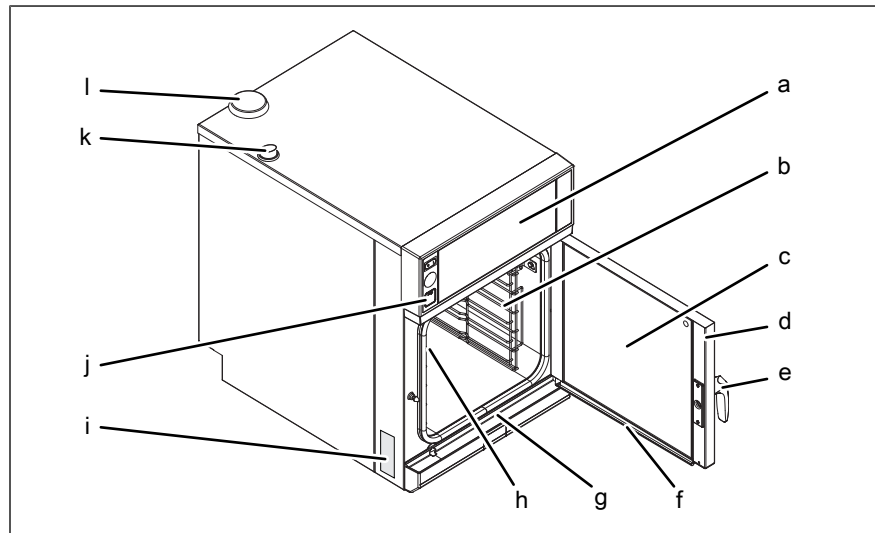

Image: Tabletop unit

- |                        |                                       |
|------------------------|---------------------------------------|
| a Operating unit       | g Drain channel, unit                 |
| b Hang-in frame        | h Core temperature sensor (concealed) |
| c Insulating disk      | i Nameplate                           |
| d Cooking chamber door | j USB port                            |
| e Door handle          | k Steam outlet nozzle                 |
| f Drain channel, door  | l Air inlet nozzle                    |

### 3.1.2 Built-in unit

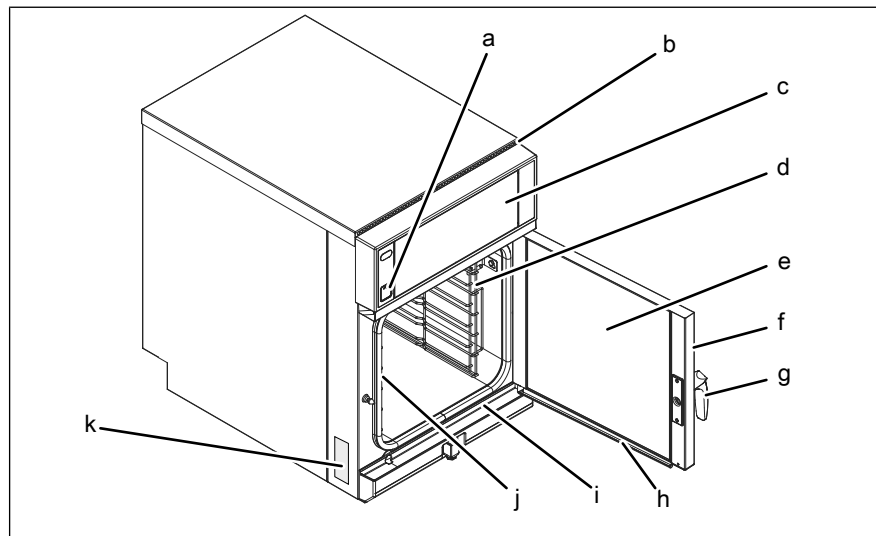

Image: Built-in unit

- |                        |                                       |
|------------------------|---------------------------------------|
| a USB port             | g Door handle                         |
| b Ventilation grille   | h Drain channel, door                 |
| c Operating unit       | i Drain channel, unit                 |
| d Hang-in frame        | j Core temperature sensor (concealed) |
| e Insulating disk      | k Nameplate                           |
| f Cooking chamber door |                                       |

### 3.2 Unit and connection data

Size	610	605
<b>Dimensions</b>		
Unit Length x Width x Height (mm (in))	787 (30,98) x 550 (21,65) x 784 (30,87)	611 (24,06) x 550 (21,65) x 784 (30,87)
Built-in unit Length x Width x Height (mm (in))	788 (31,02) x 550 (21,65) x 800 (31,5)	612 (24,09) x 550 (21,65) x 800 (31,5)
<b>Weight</b>		
Unit ≈(kg (lb))	67 (147,7)	63 (138,9)
<b>Emissions</b>		
Noise level (db(A))	< 65	
Steam output g/h (oz/h)	2070 (73,02)	1380 (48,68)
Steam output m <sup>3</sup> /h (cuft/h)	3,5 (123,5)	2,3 (81,2)
Latent heat dissipation (W)	1404	936
Sensible heat dissipation (W)	936	624
<b>With HoodIn</b>		
Steam output g/h (oz/h)	620 (21,87)	410 (14,46)
Steam output m <sup>3</sup> /h (cuft/h)	1,1 (38,8)	0,7 (24,7)

FM08-431-H

## Description of the unit

Size	610	605
Latent heat dissipation (W)	421	281
Sensible heat dissipation (W)	936	624
<b>With ventless hood</b>		
Steam output g/h (oz/h)	620 (21,87)	410 (14,46)
Steam output m <sup>3</sup> /h (cuft/h)	1,1 (38,8)	0,7 (24,7)
Latent heat dissipation (W)	421	281
Sensible heat dissipation (W)	936	624
<b>Operating environment</b>		
Temperature (°C (°F))	5 (41) — 40 (104)	
Relative humidity (%) non-condensing	95	
<b>Electrical connection</b>		
Protective system	IPX5	
Type of connection	3PE AC 50/60Hz, 3NPE AC 50/60Hz	
<b>Voltage (V)</b>	<b>200</b>	
Connected load (kW)	7	4.9
Fuse (A)	25	16
<b>Voltage (V)</b>	<b>208</b>	
Connected load (kW)	7.4	5.1
Fuse (A)	25	16
<b>Voltage (V)</b>	<b>220</b>	
Connected load (kW)	8.4	5.8
Fuse (A)	25	20
<b>Voltage (V)</b>	<b>230</b>	
Connected load (kW)	9.1	6.4
Fuse (A)	25	20
<b>Voltage (V)</b>	<b>240</b>	
Connected load (kW)	9.8	6.8
Fuse (A)	25	20
<b>Voltage (V)</b>	<b>380</b>	
Connected load (kW)	7.4	4.9
Fuse (A)	16	16
Connected load (kW)	10.1	---
Fuse (A)	16	---
<b>Voltage (V)</b>	<b>400</b>	
Connected load (kW)	7.8	5.2
Fuse (A)	16	16
Connected load (kW)	11.2	---

Size	610	605
Fuse (A)	20	---
<b>Voltage (V)</b>	<b>415</b>	
Connected load (kW)	8.1	5.4
Fuse (A)	16	16
Connected load (kW)	12	---
Fuse (A)	20	---
<b>Voltage (V)</b>	<b>440</b>	
Connected load (kW)	7.9	5.2
Fuse (A)	16	16
Type of connection	2PE AC 50/60Hz	
<b>Voltage (V)</b>	<b>208</b>	
Connected load (kW)	5.3	5.3
Fuse (A)	35	35
<b>Voltage (V)</b>	<b>240</b>	
Connected load (kW)	6.9	6.9
Fuse (A)	35	35
Type of connection	1NPE AC 50/60Hz	
<b>Voltage (V)</b>	<b>220</b>	
Connected load (kW)	5.8	3.2
Fuse (A)	35	16
<b>Voltage (V)</b>	<b>230</b>	
Connected load (kW)	6.4	3.5
Fuse (A)	35	16
<b>Voltage (V)</b>	<b>240</b>	
Connected load (kW)	6.9	3.8
Fuse (A)	35	16
<b>Softened drinking water connection</b>		
Water type	Softened drinking water, cold	
Carbonate hardness CaCO <sub>3</sub> (mmol/l (ppm))	< 0,9 (90 ppm)	
Chloride Cl (mg/l)	< 100	
Iron FE (mg/l)	< 0.2	
Connection pressure (kPa (psi))	200 (29) — 600 (87)	
Connection (")	R 3/4 outside thread	
<b>Drinking water connection</b>		
Water type	Drinking water, cold	
Carbonate hardness CaCO <sub>3</sub> (mmol/l (ppm))	< 4 (400 ppm)	
Connection pressure (kPa (psi))	200 (29) — 600 (87)	

## Description of the unit

Size	610	605
Connection (")	R 3/4 outside thread	
<b>Water consumption, steaming</b>		
Softened drinking water (l/h (gal/h))	10 (2,64)	7,5 (1,98)
<b>Water consumption, combisteaming</b>		
Softened drinking water (l/h (gal/h))	2,2 (0,58)	1,7 (0,45)
<b>Water consumption, WaveClean cleaning program</b>		
Softened drinking water (l (gal))	1,3 (0,34)	
Drinking water (l (gal))	17,7 (4,68)	
<b>Waste water connection</b>		
Waste water type	Dirty water	
Maximum length (m (ft))	1 (3,3) with downward slope of at least 5% or 3°	
Temperature resistance (°C (°F))	95 (203 )	
Connection (mm (in))	40 (1,57)	
Maximum flow rate (l/min (gal/min))	10 (2,64)	

## Floor fastening

<b>Absolutely essential for the following unit types</b>	
SPACESAVER and SPACESAVER PLUS	Only in combination with underframe, including Ventless Hood

## Basic setting of the control

Basic setting	Parameters	Standard value	Range of adjustment	Explanation
Supply voltage	14	400	100 — 500 V	Enter the local, mean voltage between the line conductors.
Date / time			yyyy - mm - dd	Year - Month - Day
			hh : mm	Hour : Minute
Altitude	2	0 — 999	0 — 999 m (3277 ft)	Request the altitude above sea level from the local weather station. If the altitude is unknown, enter 0 — 999 m (3277 ft).
			1000 m (3280 ft) — 1999 m (6557 ft)	
			2000 m (6560 ft) — 2499 m (8197 ft)	
			2500 m (8200 ft) or higher	
Volume of audible signal		Medium	Individual	Sets the volume.

Basic setting	Parameters	Standard value	Range of adjustment	Explanation
Kitchen control technology	652	Disabled	0 = Disabled 1 = Active	Indicates whether the kitchen guiding system is in use.
	659	Ethernet	0 = Ethernet 1 = Serial	Type of signal transmission (interface)
	653	1188	0 — 65535	TCP port setting
	654	254	0 — 254	Unit address
80 % power	3	100	80 %	Power can be limited to 80 % (for special applications).
			100 %	
Power optimization system	42	Off	On	If a power optimization system is connected, "On" must be selected for the unit to heat.
			Off	
Settings parameters				<ol style="list-style-type: none"> <li>1. Set parameters via the roller.</li> <li>2. Tap the "Read" button to display the set values.</li> <li>3. Specify another value via the button panel.</li> <li>4. Press the "Write" button to save the new value.</li> </ol>

### Basic setting of control (Advanced)

Basic setting	Parameters	Standard value	Range of adjustment	Explanation
Generator mode	45	0	0 = No	When a generator is used to supply electricity
			1 = Yes	
Steam elimination	48	1	0 = Low	Sets the steam elimination level
			1 = Normal	
			2 = High	
Time format	675	0	0 = 24 h	Set the 12-h or 24-h time format
			1 = 12 h	
Format for cooking program times	676	0	0 = hh:mm 1 = mm:ss 2 = automatic	Display format for cooking program times

## 4 Transporting the unit

### ⚠ CAUTION

#### Risk of property damage and personnel injury from tipping unit

- Stay clear of lifted unit.
- Move lifted unit carefully.

### NOTICE

#### Risk of property damage from improper transport

- Transport the unit upright.
- Do not tilt or stack the unit.
- Pay attention to protruding parts when transporting the unpacked unit.

Prior to transporting the unit to the installation site, ensure that:

- The roadway has adequate load-bearing capacity.
- Wall openings are large enough.

### 4.1 Transporting the unit to the installation site

→ Use suitable transport means to move unit to its installation site.

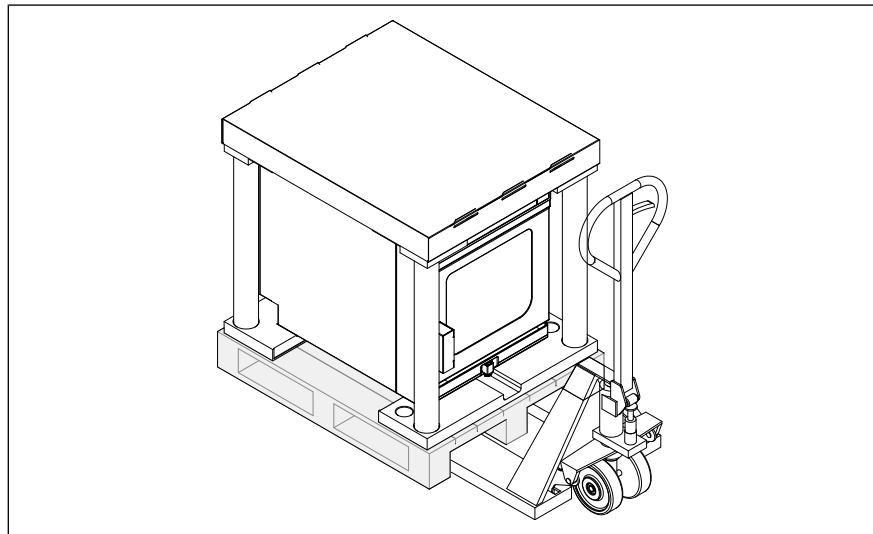

Image: Lengthwise and crosswise transport on pallet

### 4.2 Unpacking the unit

### ⚠ CAUTION

#### Risk of injury from sharp edges

- Wear protective gloves.

### INFORMATION

When unpacking the unit, inspect it for transport damage.

Do not install damaged units or put into service.



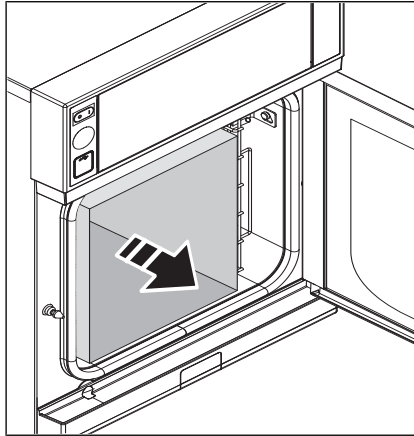

Image: Unpacking the unit

1. Remove the packaging.
2. Pull the protective film off the unit.
3. Remove all packaging material from the cooking chamber.
4. Clean the unit (See Operating instructions).
5. Enter the information from the nameplate into the Start-up operation report.
6. Enter the information from the nameplate into the Operating instructions.

## 5 Installing the unit

### ⚠ CAUTION

#### Risk of crushing from improper installation

- Protect the unit and work area during installation and alignment.

### ⚠ CAUTION

#### Risk of fire from failure to observe applicable regional fire prevention regulations

- Observe applicable regional fire prevention regulations.

### NOTICE

#### Risk of property damage from overheating of the unit

- Do not install the unit close to heat sources.

#### Planning drawing

The planning drawing and additional documents can be retrieved from the manufacturer's page on the Internet (see Legal details) by entering the number on the unit.

### 5.1 Minimum clearances

The following clearances from walls, ceilings or other equipment must be maintained when installing the unit:

- Left, right and rear: at least 50 mm (1,97 in).

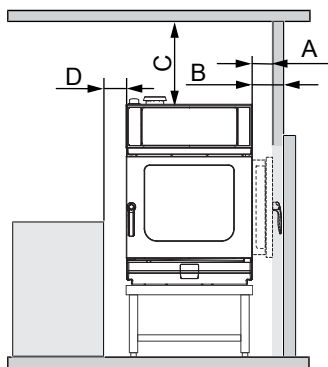

Image: Minimum clearances to walls, ceiling or units

A	B	C *	D
50 (1,97)	100 (3,94)	---	50 (1,97)
All dimensions in mm (in)			
* Depends on the kitchen ventilation system and quality of ceiling material			

## 5.2 Setting up the unit on a work surface or underframe

### ⚠ CAUTION

#### Danger due to heavy weight of the unit (over 60 kg)

- Erect the unit with several people.
- Raise / lower the unit with suitable lifting equipment.

**Prerequisite** Work surface/underframe must support the weight of the unit  
 Work surface/underframe must be level  
 Subframe installed in accordance with planning drawing

1. Lift unit.
2. Place unit on work surface or the upright bolts of the underframe.

### 5.2.1 Attaching the insertion height warning note

### ⚠ CAUTION

#### Risk of scalding due to spillage of hot cooked food

- Attach stickers if the upper insertion rails are higher than 1,6 m (5,3 ft).

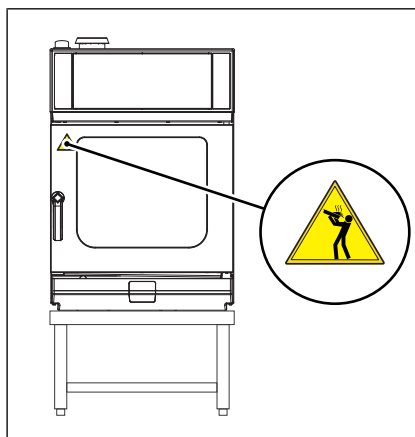

Image: Attaching the insertion height warning note

1. Clean the adhesive surface for the sticker.
2. Attach the sticker to the cooking chamber door at the height of the 1,6 m (5,3 ft).

### 5.2.2 Installing the hang-in frame

Depending on the version, the base frame can be equipped with a hang-in frame.

The hang-in the frame is used to hold containers, baking sheets and grates.

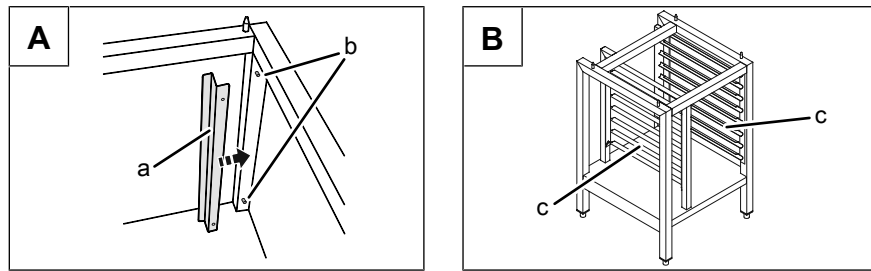

Image: A Stop profile, B Hang-in frame

a Stop profile  
b Bolt

c Hang-in frame

**Prerequisite** Pins installed in the uprights of the base frame

1. Place the stop profiles on the pins (at the back).
2. Install the support racks.

## 5.3 Fastening the unit to the floor

### 5.3.1 Securing the unit to prevent tipping

#### **WARNING**

#### **Risk of accident from insufficient fastening**

Unit can tip over

- Depending on the unit type, suitable measures must be taken to fasten the unit to the floor.
- Comply with the requirements for the condition of the floor.
- Comply with the requirements for the means of fastening.
- Follow the manufacturer's instructions for using the means of fastening.

Depending on the size, it is essential that certain combi-steamer types or combi-steamers used in combination with a Stapelkit (stacking kit), a recirculation hood, an underframe or base cabinet be secured to prevent tipping.

Unit types that must be secured to prevent tipping (see "Unit and connection data").

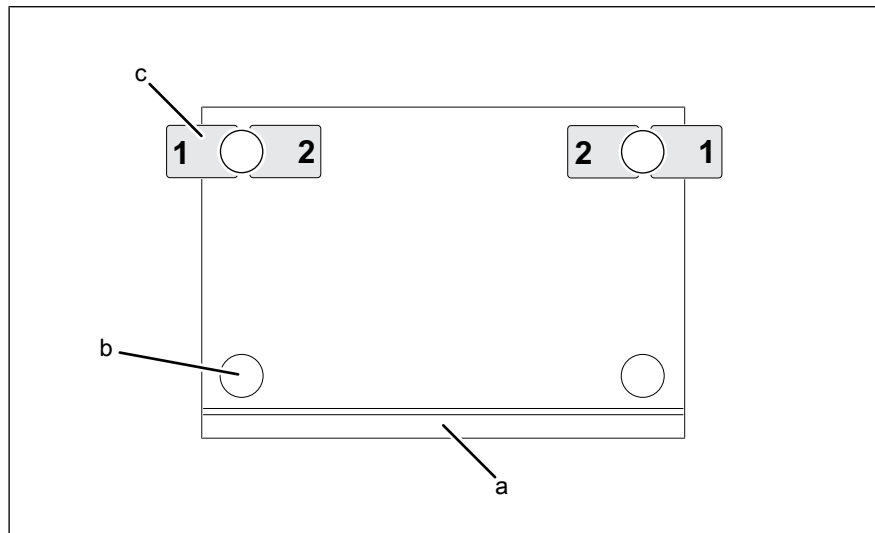

Image: Arrangement of the floor plates (view from above)

- a Cooking chamber door
- b Unit leg or underframe
- c Floor plates

To prevent the unit from tilting, a special fastening kit is supplied by the manufacturer or is available as an accessory.

The fastening kit contains two floor fasteners and all components required to bolt or bond to the floor.

The unit or underframe is fastened by means of two floor fasteners as shown in the drawing.

#### Floor without steam barrier

In the case of floors without a steam barrier, the floor plates are bolted to the floor using the bolts provided.

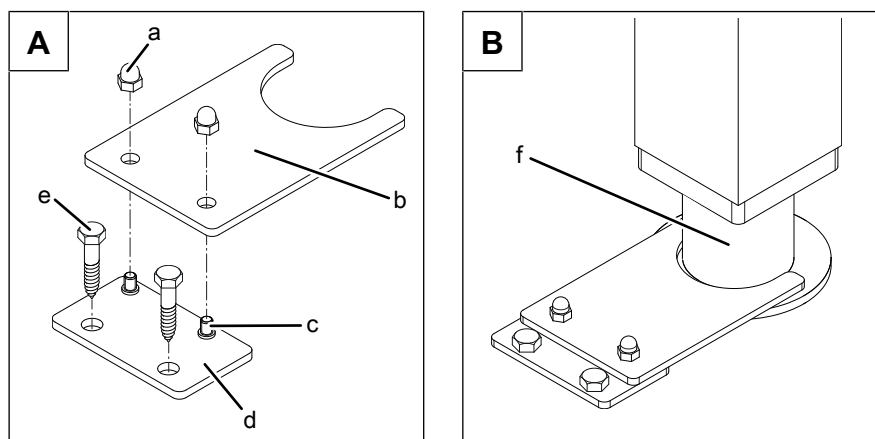

Image: A: Position of floor plate; B: floor plate bolted to the floor

- a Cap nut
- b Holding plate
- c Upright bolt
- d Floor plate
- e Lag bolt
- f Unit leg

**Prerequisite** Floor capable of accommodating the weight of the unit  
Floor must be clean and suitable for the manner fastening  
Unit set up and aligned in accordance with the planning drawing

1. Insert the floor plate from the fastening kit into the retainer as shown in the drawing.
2. Screw on the cap nuts hand-tight.
3. Align the floor fastener in position 1-1 or 2-2 on the unit leg or underframe as shown in the drawing and mark the fastening holes on the floor.
4. Mark the position of all unit legs or underframe on the floor.
5. Using suitable lifting equipment, move the unit so that the holes can be drilled in the floor.
6. Drill holes with a diameter matching that of the anchor sufficiently deep in the floor.
7. Carefully place the unit in the installation position.
8. Screw on cap nuts and remove the retainer from the floor plate.
9. Using the anchors and fastening screws provided, screw the floor plate to the floor.
10. Ensure that a tight seal against the floor has been reestablished after the fastening screws are installed.
11. Place retainer on the floor plate and secure using cap nuts.
12. Complete the start-up operation report.

### Floor with steam barrier

In the case of floors with a steam barrier, the floor plates are not screwed to the floor but fastened with the enclosed adhesive.

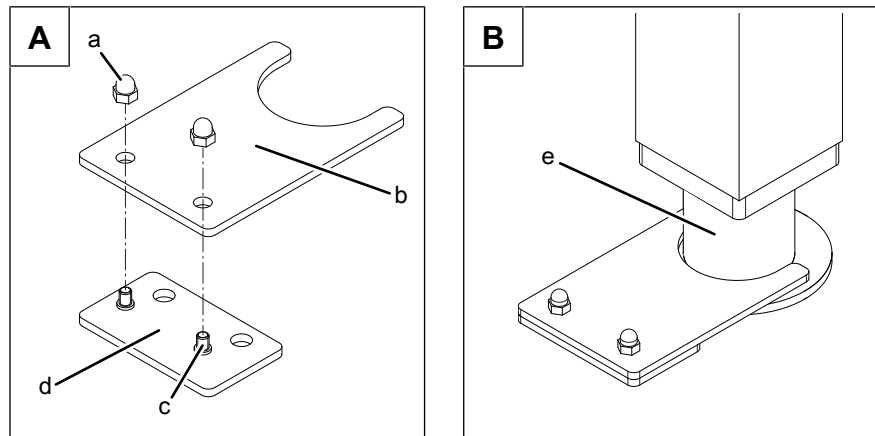

Image: A: Position of floor plate; B: floor plate glued to the floor

- a Cap nut
- b Holding plate
- c Upright bolt

- d Floor plate
- e Unit leg

**Prerequisite** Floor capable of accommodating the weight of the unit  
Floor must be clean and suitable for the manner fastening  
Unit set up and aligned in accordance with the planning drawing

1. Insert the floor plate from the fastening kit into the retainer as shown in the drawing.
2. Screw on the cap nuts hand-tight.
3. Align the floor fasteners in position 1-1 or 2-2 on the unit leg or underframe as shown in the drawing and mark the floor.
4. Screw on cap nuts and remove the retainer from the floor plate.
5. Using the adhesive provided, fasten the floor plates to the floor.
  - ↳ Follow the manufacturer's instructions regarding the adhesive.
  - ↳ Apply the adhesive in accordance with the manufacturer's instructions.
  - ↳ Observe the drying time specified in the manufacturer's instructions.
6. Place retainers on the floor plates and secure using cap units.
7. Complete the start-up operation report.

## 6 Connecting the unit

### **⚠ DANGER**

#### **Risk of personal injury and property damage from electric shock**

- Before working on the unit, ensure that the unit is dead.
- Do not operate the unit with the housing open.

### **⚠ CAUTION**

#### **Risk of injury from sharp edges**

- Wear protective gloves.

### **NOTICE**

#### **Risk of property damage from damage to the lines**

- Remove and attach housing components carefully.

### 6.1 Opening and closing the housing

#### 6.1.1 Removing and attaching the rear panel

Remove the rear panel.

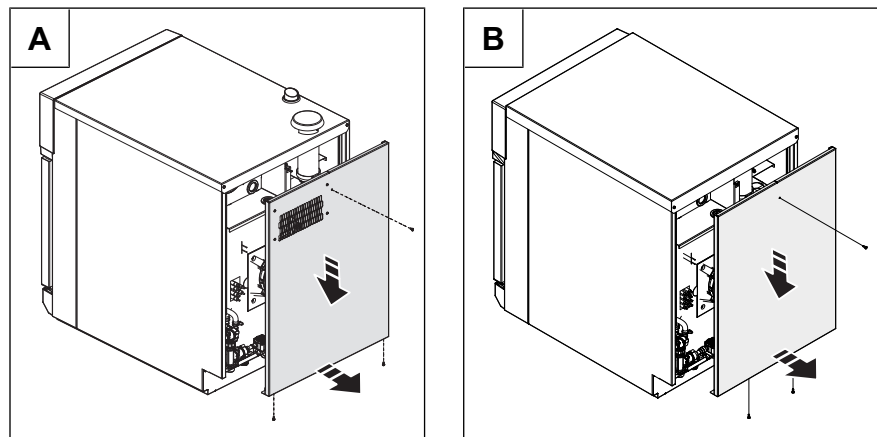

Image: Remove the rear panel, A Tabletop unit, B Built-in unit

1. Unscrew the screws in the back wall.
2. Holding the bottom edge, carefully pull the back wall down and then forward.

Attaching the rear panel

### **NOTICE**

#### **Risk of property damage from leaky housing**

- Check seals when attaching the housing parts.
- Replace damaged seals.



1. Place the top of the back wall in position first and then press against the seal at the bottom.
  2. Slide the back wall up.
  3. Install screws in the back wall.
- ↳ The back wall must be in contact with the unit on all sides.

### 6.1.2 Removing and attaching the unit cover

#### Removing the unit cover on a tabletop unit

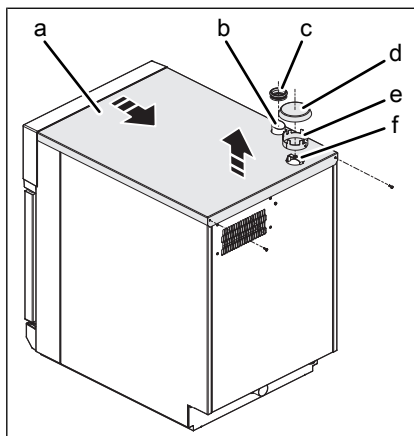

Image: Removing the unit cover

- |                       |                    |
|-----------------------|--------------------|
| a Unit cover          | d Lid              |
| b Steam outlet nozzle | e Ventilation ring |
| c Seal                | f Air inlet nozzle |

1. Unscrew the lid from the air inlet nozzle.
2. Remove the ventilator ring.
3. Unscrew the screws on the unit cover.
4. Carefully remove the unit cover.

#### Attaching the unit cover on a tabletop unit

### NOTICE

#### Risk of property damage from leaky housing

- Check seals when attaching the housing parts.
- Replace damaged seals.

1. Brush the seal on the steam outlet nozzle with an acid-free slip agent.
2. Carefully push the unit cover over the steam outlet nozzle and air inlet nozzle.
  - ↳ The air inlet nozzle must be pushed through the cut-outs on the unit cover.
3. Press the unit cover onto the housing.
4. Screw in the screws on the unit cover.
  - ↳ The unit cover must be in contact with the unit on all sides.

- Put the ventilator ring on with the cut-outs facing upwards and ensure that it can not be rotated.
- Screw the lid onto the air inlet nozzle.

### Removing the unit cover on a built-in unit

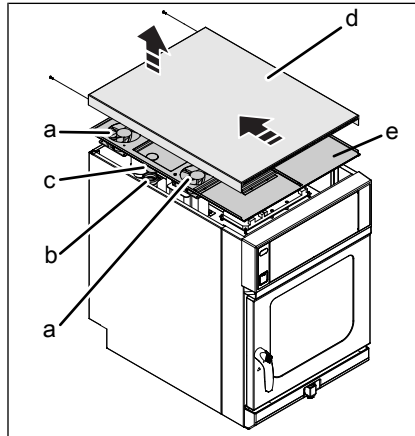

Image: Removing the unit cover

- |                       |                |
|-----------------------|----------------|
| a Fan                 | d Unit cover   |
| b Seal                | e Air diverter |
| c Steam outlet nozzle |                |

- Unscrew the screws in the unit cover.
- Carefully remove the unit cover.

### Attaching the unit cover on a built-in unit

## NOTICE

#### Risk of property damage from leaky housing

- Check seals when attaching the housing parts.
- Replace damaged seals.

- Check that the seal on the steam outlet nozzle is seated properly.
- Apply a film of acid-free lubricant to the seal on the steam outlet nozzle.
- Slide the unit cover forward.
- Carefully position the unit cover flush with the steam outlet nozzle.
- Install screws in the unit cover.

↳ The unit cover must be in contact with the unit on all sides.

## 6.2 Making the electrical connection

### Electrical installation work

Electrical installation work on the electric system and the unit may only be performed by a specialist company, which is approved by the electric utility company in the particular region. The applicable regional

regulations, standards and guidelines must be observed, as well as the connection conditions imposed by the electric utility company responsible.

**Technical qualifications for electrical installation tasks**

Electrical installation tasks on the electrical system and the unit may be carried out only by an electrician provided by the specialist company contracted.

The unit must be connected in accordance with the information on the nameplate and the instructions of this manual.

**Wiring diagram**

The wiring diagram is included with the unit.

The wiring diagram and additional documents are available on the manufacturer's Internet page by entering the serial number of the unit (see Imprint).

**Electrical connection line**

Minimum requirements for the unit's electrical connection line to the electrical supply mains:

Connection	Electrical connection line
Permanent connection for fixed installation with a cable from the unit to a separate connection box.	Rubber sheath cable, oil-resistant, shrouded and flexible in accordance with IEC 60245-57 (for example: H05RN-F).
Connection of the unit with a connector.	

**Permanent connection**



**Risk of property damage and personal injury from improper installation**

- In the case of a permanent connection, install an all-pin separating device before the unit.

Install an all-pin separating device if the unit will be connected permanently to the electrical supply mains.

**Plug-in connection**



**Risk of property damage and personal injury from improper installation**

- The plug-in connection must be readily accessible.

If the unit is connected with a plug to the electrical supply mains, use plugs and sockets according to IEC60309.

The socket must be readily accessible so that the unit can be disconnected from the electrical supply mains at any time.

### Insulation monitoring

In the case of an unearthed network (IT network), the unit can be incorporated into the insulation monitoring.

### Fault current device

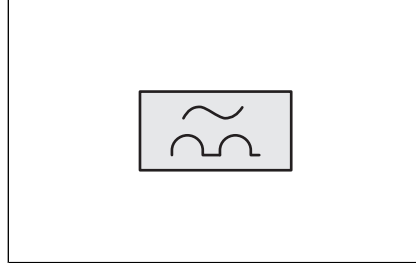

Image: RCD switch type A circuit symbol

The unit can be connected to a fault current device.

If a residual-current circuit breaker is used, the residual-current circuit breaker installed must be type A (RCD type A ) to ensure that AC fault currents and pulsating DC fault currents are detected.

If the unit is connected to electrical supply mains without a neutral conductor, a type B fault current circuit breaker (RCD type B), which is sensitive to all types of current, must be installed.

The unit generates a small fault current through use of special electronic components. To ensure that the residual current device does not trip during normal operation, each unit should have its own residual current device.

### Potential equalization

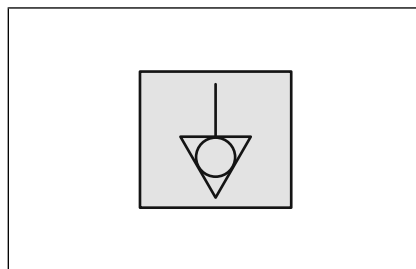

Image: Potential equalization symbol

The unit can be included in a potential equalization system by means of appropriately sized wiring.

## 6.2.1 Connecting the electrical connection line

### DANGER

#### Risk of operator injury and property damage from electric shock

- Before connecting, make sure that the connection point at the installation site is dead.
- Make sure that the connection line is undamaged.

**⚠ DANGER****Risk of personal injury and property damage from electric shock**

- Before connecting, ensure that the electrical connection line is dead.
- Ensure that the electrical connection line is undamaged.

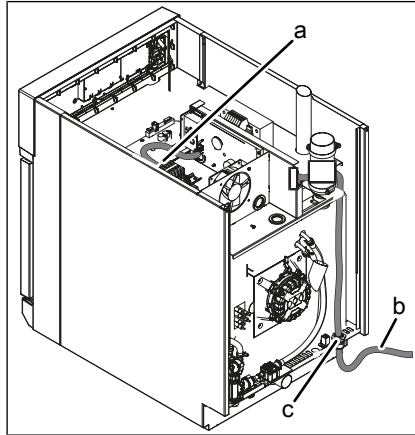

Image: Electrical connection line

- |                              |               |
|------------------------------|---------------|
| a Connection terminals       | c Cable entry |
| b Electrical connection line |               |

**Prerequisite** Electrical connection point at installation site dead  
Voltage matches the data on the nameplate

1. Connect the electrical connection line to the connection point at the installation site in accordance with the circuit diagram.
  - ↳ A suitable connector can also be attached to the electrical connection line.
2. Complete the start-up operation report.

**Connecting the connection line available at the installation site****INFORMATION**

If a connection line is already available at the installation site, the minimum requirements for the electrical connection line must be observed and complied with.

**Prerequisite** The electrical connection line meets the minimum requirements  
Electrical connection line dead  
Rear panel removed  
Unit cover removed

1. Disconnect the factory connection line and carefully remove it from the unit.
  - ↳ Note the routing position of the connection line.
2. Pull the electrical connection line into the unit through the cable gland.
3. Route the connection line so that it corresponds exactly to the factory routing.

4. Secure the connection line with cable ties.
5. Connect connection cable in accordance with the circuit diagram.
6. Tighten threaded cable connection to provide strain relief.
7. Close the housing (see "Opening and closing the housing").
8. Complete the start-up operation report.

### 6.2.2 Connecting the power optimization system

#### DANGER

#### Risk of personal injury and property damage from electric shock

- Before working on the unit, ensure that the unit has been disconnected from the power supply.

#### DANGER

#### Risk of personal injury and property damage from electric shock

- Before connecting, ensure that the electrical connection line is dead.
- Ensure that the electrical connection line is undamaged.

The unit can be connected to a power optimization system designed to DIN 18875 with a potential-free contact. The potential-free contact is used to link the unit to the control. The required cable length in the unit for the power optimization system corresponds to the height of the unit.

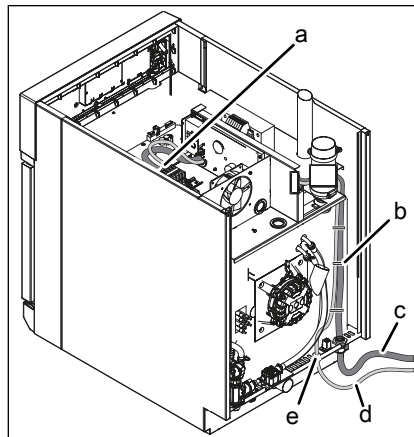

Image: Connecting the power optimization system

- |   |   |
|---|---|
| a Connection terminals X2 for power optimization system | d Connection line for power optimization system |
| b Cable tie   | e Cable entry                                   |
| c Electrical connection line                            |   |

**Prerequisite** Unit dead  
Connection line dead  
Unit cover open  
Back wall open

1. Press out appropriate opening in the bottom.
2. Screw in appropriate threaded cable connection.

3. Guide connection cable into the unit through the threaded cable connection.
4. Route connection line to the connection terminals parallel to the electrical connection line.
5. Connect connection cable in accordance with the circuit diagram.
6. Secure connection cable with cable tie.
7. Tighten threaded cable connection to provide strain relief.
8. Close housing.
9. Log on to power optimization system in basic control setting (see "Establishing the basic control setting").
10. Complete the start-up operation report.

### 6.2.3 Connecting the potential equalization

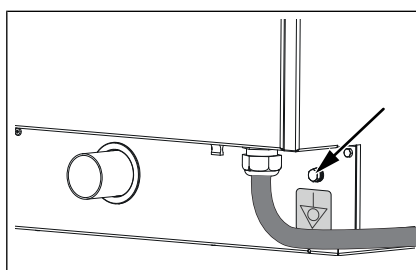

Image: Connecting the potential equalization

1. Route and connect the potential equalization line to the marked connection.
2. Fill out the Start-up operation report.

### 6.3 Connecting the kitchen guiding system

The units can be connected to a kitchen guiding system using an RJ45 plug.

#### Minimum requirements for the network cable

Type of network	Ethernet
Cable quality	4-pair shrouded patch cable Cat-5 S/FTP
Connection to unit	Shrouded RJ45 connector

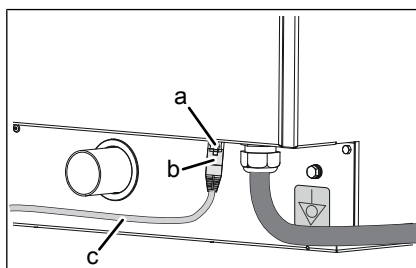

Image: Connecting the kitchen guiding system

- a RJ45 socket
- b RJ45 connector
- c Network cable

1. Connect the network cable to the RJ45 connector on the unit.

2. Log on to the network in the basic control setting (see "Establishing the basic control setting").
3. Complete the start-up operation report.

### 6.4 Performing the basic setting of the control

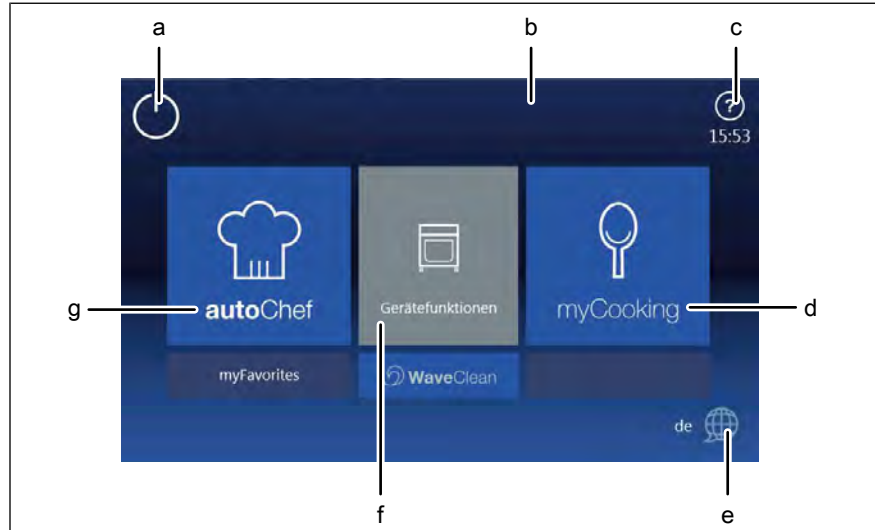

Image: Main menu

- |   |                    |   |                           |
|---|--------------------|---|---------------------------|
| a | Stand-by button    | e | Language selection button |
| b | Information strip  | f | "Unit functions" button   |
| c | FlexiHelp button   | g | "autoChef" button         |
| d | "myCooking" button |   |                           |

#### 6.4.1 Changing the basic setting of the control

By entering the password "2100", the basic setting for the installation can be displayed and changed.

### INFORMATION

The basic settings are made in the dialogue.

Advanced settings are made via the parameters for the settings.

**Prerequisite** Unit is on

The Main menu is displayed

1. Tap the "Unit functions" button.  
↳ The *Unit functions* menu is displayed.
2. Tap the "Unit settings" field.  
↳ The *PIN* window opens.
3. Enter the password.
4. Tap the *Confirm* button.  
↳ The *Unit settings* menu is displayed.  
↳ The basic settings can be changed (see "Unit and connection data").
5. Fill out the Start-up operation report.



## 6.5 Making the water connection

### Drinking water installation tasks

Drinking water installation tasks on drinking water lines and the unit may only be performed by a specialist company, which is approved by the drinking water utility company in the particular region. The applicable regional regulations, standards and guidelines must be observed, as well as the connection conditions imposed by the drinking water utility company responsible.

### Technical qualifications for drinking water installation tasks

Drinking water installation tasks on drinking water lines and the unit may be carried out only by a water specialist provided by the specialist company contracted.

The unit has a connection for permanent installation to the drinking water supply.

The unit is equipped with a permanent connection for:

- Softened drinking water for steam generation
- Drinking water for cooling, rinsing and cleaning

### CAUTION

#### Hygiene risk from contaminated drinking water

- The connection to the drinking water supply must be equipped with a back-flow preventer.

### NOTICE

#### Risk of property damage from the wrong water quality

- Ensure that the water quality complies with the unit and connection data.

### INFORMATION

Always connect both water connections to the unit.

### 6.5.1 Connecting the drinking water connection line

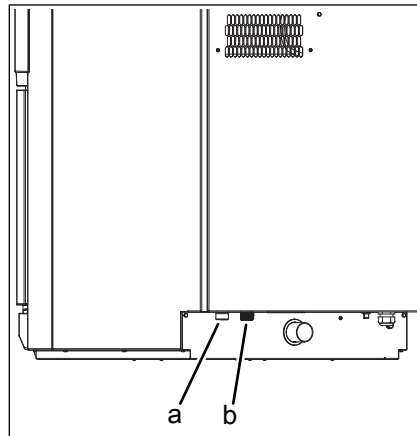

Image: Water connection

a Drinking water connection

b Softened drinking water connection

**Prerequisite** Water pressure complies with specifications (see "Unit and connection data")  
Backflow preventer installed  
Pressure-resistant connection lines suitable for tap water are available

1. Connect the connection lines to the drinking water taps using seals.
2. Flush the connection lines thoroughly.
3. Insert dirt filters into the water connections on the unit.
4. Connect the drinking water connection line to the unit.
5. Connect the connection line for softened drinking water to the unit.
6. Open the tap water valves and check the threaded connectors for leaks.
7. Fill out the Start-up operation report.

### 6.5.2 Connecting softened drinking water to both connections

If only softened drinking water is available at the installation site, use a T-piece to connect both water connections on the unit to each other.

**Prerequisite** Water pressure complies with specifications (see "Unit and connection data")  
Backflow preventer installed  
Pressure-tight connection line suitable for drinking water is available

1. Connect the connection line to the tap for softened drinking water using a seal.
2. Flush the connection line thoroughly.
3. Insert dirt filters into the water connections on the unit.
4. Connect T-piece to the unit.

5. Connect the connection line for softened drinking water to the T-piece using a seal.
6. Open the drinking water tap and check the threaded fittings for leakage tightness.
7. Fill out the Start-up operation report.

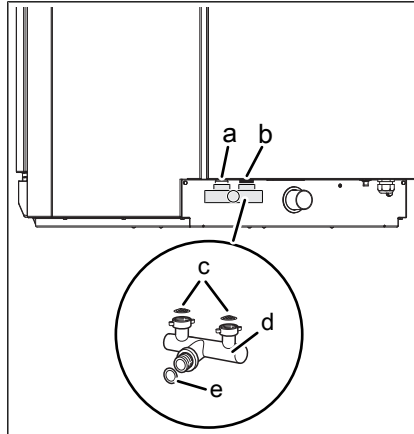

Image: Connecting softened drinking water at two locations

- |                                      |           |
|--------------------------------------|-----------|
| a Drinking water connection          | d T-piece |
| b Softened drinking water connection | e Seal    |
| c Dirt filter                        |           |

## 6.6 Making the waste water connection

### Waste water installation tasks

Waste water installation tasks on waste water systems and the unit may only be carried out by a specialized company that is responsible for waste water systems. The applicable regional regulations, standards and guidelines must be observed, as well as the connection conditions imposed by the operator of the waste water company responsible.

### Technical qualifications for waste water installation tasks

Waste water installation tasks on waste water lines and the unit may be carried out only by a waste water specialist provided by the specialist company contracted.

## Connecting the unit

### 6.6.1 Connecting the waste water line to a permanent connection

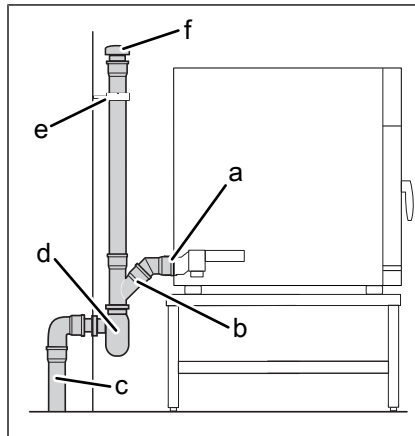

Image: Waste water line to a permanent connection

- |   |                        |   |                |
|---|------------------------|---|----------------|
| a | Waste water connection | d | Siphon         |
| b | Waste water line       | e | Pipe clamp     |
| c | Waste water mains      | f | Vacuum breaker |

## INFORMATION

Install a vacuum breaker in the waste water line.

**Prerequisite** The waste water line complies with the specifications (see "Unit and connection data")

1. Install waste water line up to connection to the waste water system.
2. Secure waste water line with pipe clamps.
3. Fill the siphon of the unit with drinking water.
4. Fill out the Start-up operation report.

### 6.6.2 Connecting a waste water line with an unobstructed discharge

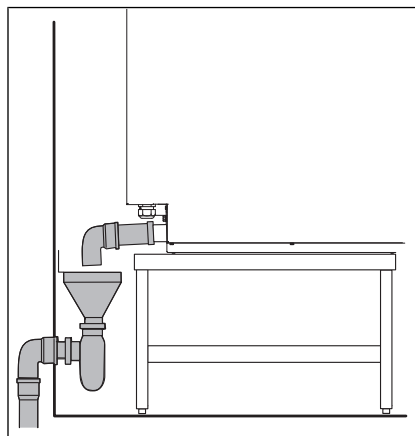

Image: Connecting the waste water line to the discharge funnel

- |   |                        |   |                             |
|---|------------------------|---|-----------------------------|
| a | Waste water connection | d | Waste water mains           |
| b | Waste water line       | e | Siphon on waste water mains |
| c | Funnel siphon          | f | Discharge funnel            |

**Prerequisite** The waste water line complies with the specifications (see "Unit and connection data")

1. Connect the discharge funnel with waste trap to the sewer system.
2. Connect the waste water line to the unit and extend it to the discharge funnel.
3. Secure waste water line with pipe clamps.
4. Install outlet of the waste water line 20 mm ( 0,8 in) above the discharge funnel.
5. Fill the discharge funnel with tap water.
6. Fill out the Start-up operation report.

# 7 Installing the unit

### ⚠ CAUTION

#### Danger due to heavy weight of the unit (over 60 kg (132 lb))

- Erect the unit with several people.
- Raise / lower the unit with suitable lifting equipment.

### ⚠ CAUTION

#### Risk of crushing from improper installation

- Protect the unit and work area during installation and alignment.

### ⚠ CAUTION

#### Risk of crushing fingers and hands when lifting and lowering the unit on the shelf plate

- Always lift and lower the unit (with suitable lifting equipment) carefully with two people.

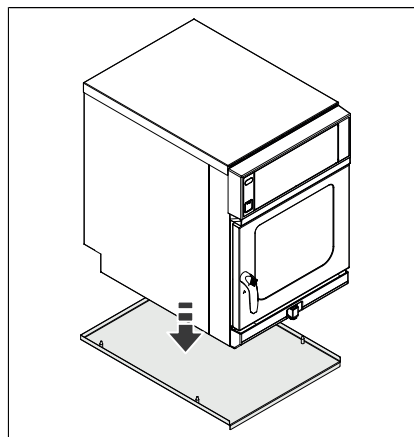

Image: Placing the unit on the slide-in plate

#### **Prerequisite** Electrical connection made

Water connection made or prepared

Waste water connection made or prepared

Housing closed

1. Place unit over the upper right bolts on the slide-in plate.  
↳ Bent edge of slide-in plate is at front.
2. Lift unit with slide-in plate and slide into place.
3. Complete remaining work for connecting the unit (see "Connecting the unit").
4. Complete the start-up operation report.

## 8 Testing the function

### DANGER

**Risk of personal injury and property damage from unsuccessful operational check**

- Do not put the unit into service.
- Contact customer service.

**Prerequisite** Electrical connection made  
 Water connection made  
 Waste water connection made  
 Unit cleaned

### 8.1 Checking the controls

1. Switch on the unit and start any cooking program (see operating instructions).
  - ↳ Set the cooking chamber temperature to a higher temperature than the current cooking chamber temperature.
  - ↳ The unit heats up.
  - ↳ Once the set temperature is reached, heating switches off.
  - ↳ The temperature no longer increases.
  - ↳ The controls are functioning.
2. Switch off the unit.
3. Fill out the Start-up operation report.

### 8.2 Checking the inspection of the cooking chamber door

1. Switch on the unit and start any cooking program (see operating instructions).
  - ↳ The unit heats up.
  - ↳ The fan is turning.
2. Open the cooking chamber door during operation.
  - ↳ The unit shuts off the heating function.
  - ↳ The fan comes to a stop.
  - ↳ The monitoring of the cooking chamber door is functioning.
3. Close the cooking chamber door.
4. Switch off the unit.
5. Fill out the Start-up operation report.

### 8.3 Heating and rinsing the unit

1. Switch on the unit.
2. Tap the "Manual cooking" button.
  - ↳ The Manual cooking menu is displayed.

## Testing the function

---

3. Run the unit in the Steaming mode for 15 minutes at 100 °C (212°F).
4. Rinse the cooking chamber thoroughly with clear water.
5. Run the unit in the hot air mode for 5 minutes at 180 °C (356°F).
6. Open the cooking chamber door and leave it ajar until the unit is used again.
7. Fill out the start-up operation report.



## 9 Putting the unit into service

### INFORMATION

If the unit is not put into service immediately after being connected and the function check, all inspections must be repeated.

- Prerequisite**
- Electrical connection made
  - Water connection made
  - Wastewater connection made
  - Exhaust air connection made (if required by the customer)
  - Function checked successfully
  - Housing closed

1. Instruct operator.
2. Fill out the Start-up operation report.

### 9.1 Nameplate

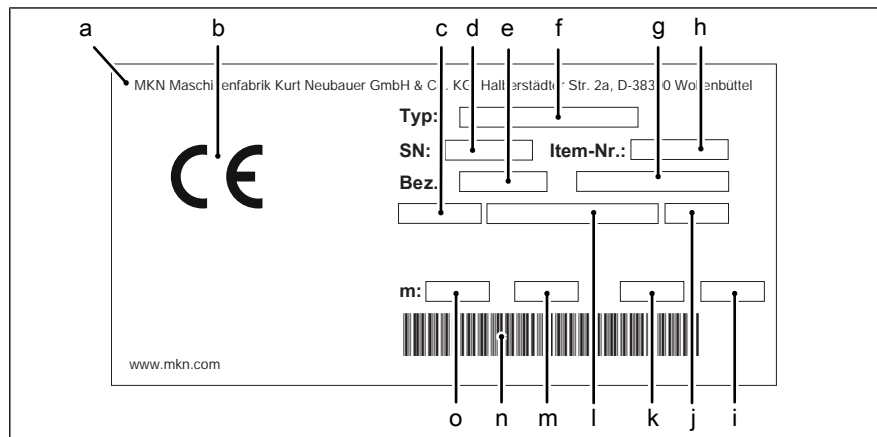

Image: Nameplate information

- |                             |                          |
|-----------------------------|--------------------------|
| a Manufacturer              | i Frequency              |
| b CE mark                   | j Barcode                |
| c Electrical connected load | k Country of destination |
| d Serial number             | l Type of connection     |
| e Equipment abbreviation    | m Protection class       |
| f Type number               | n Barcode                |
| g Equipment designation     | o Weight                 |
| h Item number               |                          |

### 9.2 Filling out the Start-up operation report

General information	Yes	No
Information from the nameplate entered?	<input type="checkbox"/>	<input type="checkbox"/>
SN: _____ Typ: _____		
E: _____		
Bez: _____		
Item-Nr.: _____ (if listed)		

FM08-431-H

## Putting the unit into service

General information		Yes	No
Obvious damage to the unit? What and where?: _____		<input type="checkbox"/>	<input type="checkbox"/>
Unit levelled?		<input type="checkbox"/>	<input type="checkbox"/>
General information		Yes	No
Unit fastened to floor?		<input type="checkbox"/>	<input type="checkbox"/>
<b>secured against tipping</b> <input type="checkbox"/> Screwed to floor <input type="checkbox"/> Glued to floor	<b>secured against shifting</b> <input type="checkbox"/> Screwed to floor <input type="checkbox"/> Glued to floor		
Electrical connection		Yes	No
Electrical connection made properly?		<input type="checkbox"/>	<input type="checkbox"/>
<input type="checkbox"/> Potential equalization	<input type="checkbox"/> Power optimization system		
<input type="checkbox"/> Potential-free contact	<input type="checkbox"/> _____		
Electrical connections made properly?		<input type="checkbox"/>	<input type="checkbox"/>
Fault current device connected directly before this unit?		<input type="checkbox"/>	<input type="checkbox"/>
Fault current device connected before this and other units?		<input type="checkbox"/>	<input type="checkbox"/>
Kitchen guiding system		Yes	No
Kitchen guiding system connected properly?		<input type="checkbox"/>	<input type="checkbox"/>
Basic setting of the control		Yes	No
Temperature unit set?		<input type="checkbox"/>	<input type="checkbox"/>
<input type="checkbox"/> °C	<input type="checkbox"/> °F		
Date and time set?		<input type="checkbox"/>	<input type="checkbox"/>
Software version identified?		<input type="checkbox"/>	<input type="checkbox"/>
Version: _____			
Altitude set?		<input type="checkbox"/>	<input type="checkbox"/>
<input type="checkbox"/> 0 — 999 m (3277 ft)	<input type="checkbox"/> 1000 m (3280 ft) — 1999 m (6557 ft)		
<input type="checkbox"/> 2000 m (6560 ft) — 2499 m (8197 ft)	<input type="checkbox"/> 2500 m (8200 ft) or higher		
80% power set?		<input type="checkbox"/>	<input type="checkbox"/>
<input type="checkbox"/> 100 %	<input type="checkbox"/> 80 %		
Supply voltage set?		<input type="checkbox"/>	<input type="checkbox"/>
Voltage: _____ V			
Audible signal volume set?		<input type="checkbox"/>	<input type="checkbox"/>
<input type="checkbox"/> Low	<input type="checkbox"/> High		
Signal tone selected?		<input type="checkbox"/>	<input type="checkbox"/>

FM08-431-H

Basic setting of the control		Yes	No
Volume unit set?		<input type="checkbox"/>	<input type="checkbox"/>
<input type="checkbox"/> ml	<input type="checkbox"/> fl.oz. (Imperial)		
<input type="checkbox"/> fl.oz. (U.S.)			
Power optimization system set?		<input type="checkbox"/>	<input type="checkbox"/>
<input type="checkbox"/> On	<input type="checkbox"/> Off		
Water filter maintenance set?		<input type="checkbox"/>	<input type="checkbox"/>
<input type="checkbox"/> No maintenance message	<input type="checkbox"/> Maintenance message at: _____ l (gal)		
Network configuration set?		<input type="checkbox"/>	<input type="checkbox"/>
<input type="checkbox"/> DHCP	IP address: _____		
Subnet mask: _____	Gateway: _____		
Kitchen guiding system set?		<input type="checkbox"/>	<input type="checkbox"/>
<input type="checkbox"/> Active	<input type="checkbox"/> Disabled		
<input type="checkbox"/> Ethernet	<input type="checkbox"/> Serial		
TCP port: _____	Unit address: _____		
Unit address: _____			

Water connection		Yes	No
Connection pressure within indicated range?		<input type="checkbox"/>	<input type="checkbox"/>
Connection pressure: _____ ( _____ ) kPa (psi)			
Water connection made properly?		<input type="checkbox"/>	<input type="checkbox"/>
Lines and connections leak-tight?		<input type="checkbox"/>	<input type="checkbox"/>
Water connections connected with T-piece?		<input type="checkbox"/>	<input type="checkbox"/>
<input type="checkbox"/> Connected only to softened drinking water	<input type="checkbox"/> Connected only to drinking water		

Waste water connection		Yes	No
Waste water connection made in a technically correct manner?		<input type="checkbox"/>	<input type="checkbox"/>
<input type="checkbox"/> Siphon in the building	<input type="checkbox"/> Vacuum breaker		
<input type="checkbox"/> Funnel drain	<input type="checkbox"/> Floor drainage channel		
Connection size of waste water line: _____ mm (in)			

Function check		Yes	No
Controls functioning?		<input type="checkbox"/>	<input type="checkbox"/>
Monitoring of cooking chamber door functioning?		<input type="checkbox"/>	<input type="checkbox"/>
Unit heated and rinsed?		<input type="checkbox"/>	<input type="checkbox"/>

FM08-431-H

## Putting the unit into service

Final notes	Yes	No
Was the unit put into service?	<input type="checkbox"/>	<input type="checkbox"/>
Comments:		
Operator trained?	<input type="checkbox"/>	<input type="checkbox"/>

Electrical installation was made by:			
Company	Installation fitter	Place, date	Signature

The connection to a kitchen guiding system was made by:			
Company	Installation fitter	Place, date	Signature

Water installation was made by:			
Company	Installation fitter	Place, date	Signature

Wastewater installation was made by:			
Company	Installation fitter	Place, date	Signature

Function check was made by:			
Company	Installation fitter	Place, date	Signature

Operator was trained by:			
Company	Installation fitter	Place, date	Signature









Henny Penny Corporation  
P.O.Box 60  
Eaton, OH 45320  
USA

Phone +1 937 456-8400  
Fax +1 937 456-8402

Toll free in USA  
Phone +1 937 417-8417  
Fax +1 937 417-8434

[www.hennypenny.com](http://www.hennypenny.com)



Henny Penny Corp., Eaton, Ohio 45320, Revised 2/24/2020